



















Industrial Enclosures

	Eclipse Junior Series Single Door Enclosures - NEMA 12, 13, 4 2
	1414 Series JIC Enclosures, Clamped, Lift Off Cover - NEMA 12, 13 4
	1414 N4 Series JIC Enclosures, Clamped, Lift Off Cover - NEMA 4, 13 6
	1414 PH Series JIC Enclosures, Continuous Hinge, Clamped Cover - NEMA 12, 13 8
	1414 N4 PH Series JIC Enclosures, Continuous Hinge, Clamped Cover - NEMA 4, 13 10
	1414 SC Series JIC Enclosures, Lift Off, Screw Cover - NEMA 12, 13 12
	1436/1438 Series Junction Boxes, Lift Off, Screw Cover - NEMA 12, 13 14
	1418J Series, Large JIC Enclosures - NEMA 12 16
	Eclipse Series, Single Door Enclosures with Gland Plate - NEMA 12, 4 18
	Eclipse Series, Single Door Enclosures - NEMA 12, 4 22
	Eclipse Series, Single Window Door Enclosures with Gland Plate - NEMA 12, 4 26
	Eclipse Series, Single Window Door Enclosures - NEMA 12, 4 28
	Eclipse Series, Two Door Enclosures with Gland Plate - NEMA 12 30
	Eclipse Series, Two Door Enclosures - NEMA 12, 4 32
	Eclipse Series Accessories - NEMA 12, 4 34
	Eclipse Master Selection Table 38

	Series 2000, Single Door Enclosures - NEMA 12, 4 40
	Series 2000 Accessories - NEMA 12, 4 42-45
	Series 2000 Master Selection Table 46
	1418 Series, Single Door Enclosures - NEMA 12, 13 48
	1418 N4 Series, Single Door Enclosures - NEMA 12, 4 50
	1422 Series, Two Door Wallmount Enclosures - NEMA 12 52
	1422 Series, Two Door Floormount Enclosures - NEMA 12 54
	1422 Series, Two Door Floormount Enclosures - NEMA 12, 4 56
	1418 Series, Single Door Freestanding Enclosures, Single or Dual Access - NEMA 12 58
	1418 N4 Series, Single Door Freestanding Enclosures - NEMA 12, 4 60
	1418 Series, Two Door Freestanding Enclosures - NEMA 12 62
	1418 Series Freestanding Enclosures Accessories - NEMA 12, 4 64
	1422 MD Series Multiple Door Enclosures - NEMA 12 66

Eclipse Junior Series - NEMA 12, 13, 4 Single Door Enclosures

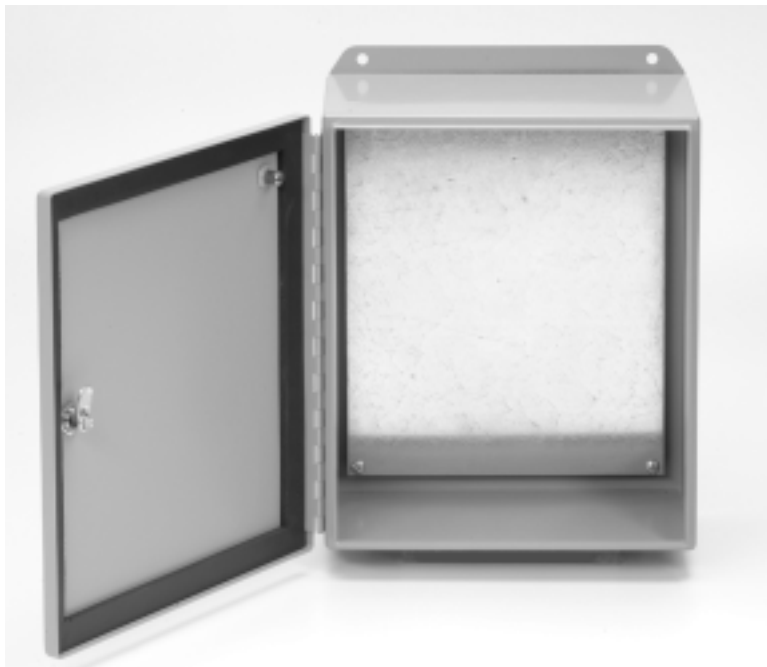

Inner
Panel
Included



Application

- Designed to enclose electrical and/or electronic equipment and protect against harsh, industrial environments.
- For use as instrument enclosures, electric, hydraulic or pneumatic control housings, electrical junction boxes or terminal wiring enclosures.
- Impressive styling features make the Eclipse Junior a suitable addition to any high-tech equipment installation.
- For high temperature applications, a gasket retainer may be required, please refer to factory.

Standards

- UL 508 Type 3R, 4, 12 and 13
- CSA Type 3R, 4, 12 and 13
- **Complies with**
 - NEMA Type 3R, 4, 12 and 13
 - IEC 529, IP66

Construction

- Body and cover are formed from 16 gauge steel.
- Smooth, continuously welded seams without knockouts, cutouts, or holes.
- Formed lip on enclosure to exclude flowing liquids and contaminants.
- 14 gauge welded brackets provide for enclosure mounting.
- Continuously hinged cover has 304 stainless steel hinges and provides 180° opening
- Door latches feature the added safety of quarter turn slot requiring use of tool for opening.
- Quarter turn latches formed from black zinc diecast.
- Oil resistant gaskets are permanently secured.
- Models larger than 4"x4" include a removable 14 gauge galvanized inner panel.
- Internal threaded weld studs are provided for mounting inner panels.
- A bonding stud is provided on the door and a grounding stud is provided on the enclosure.
- Includes grounding kit and a hardware kit with panel mounting screws.

Finish

- Cover and enclosure are finished in recoatable smooth ANSI/ASA 61 gray powder coating.
- Inner panels are unpainted galvanized steel.

Accessories

- Breather kits...see page **374**
- Filter fans...see page **360-367**
- Louvered ventilating plates
...see page **396**
- Padlocking provision
...see page **383**
- Terminal kit assemblies
...see page **386**
- Thermostats...see page **374**
- Wing knob lock...see page **383**

Eclipse Junior Series - NEMA 12, 13, 4

Single Door Enclosures

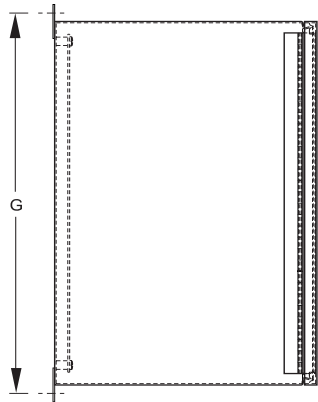

Hinge Side View

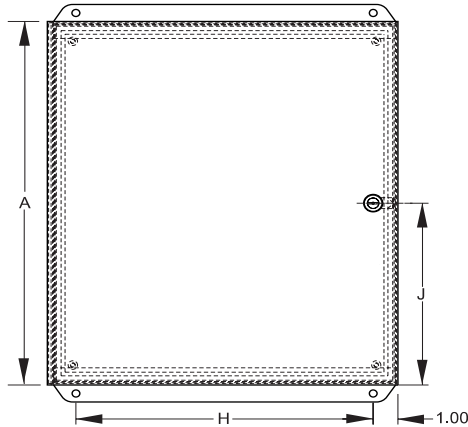

Front View

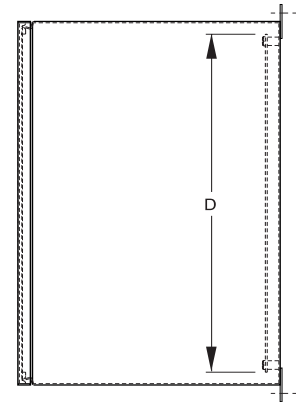

Latch Side View

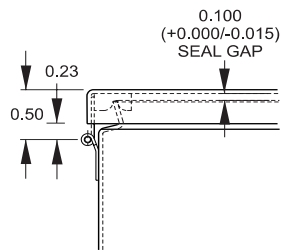

Hinge Side

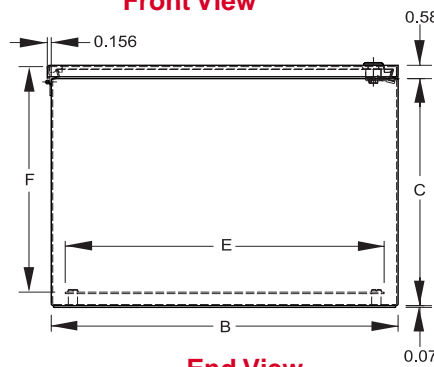

End View

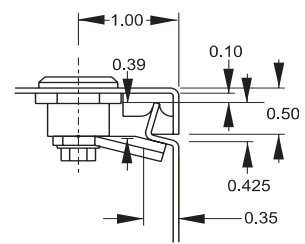

Quarter Turn Latch

Part No.	Overall Dimensions			Panel Size				J	F	Ship Wt. lbs.
	A	B	C	H	G	D	E			
EJ443	4.00	4.00	3.00	2.00	4.75	—	—	2.00	—	2
EJ643	6.00	4.00	3.00	2.00	6.75	4.88	2.88	3.00	2.92	2
EJ683	6.00	8.00	3.50	6.00	6.75	4.88	6.75	3.00	3.42	5
EJ863	8.00	6.00	3.50	4.00	8.75	6.75	4.88	4.00	3.42	5
EJ444	4.00	4.00	4.00	2.00	4.75	—	—	2.00	—	3
EJ644	6.00	4.00	4.00	2.00	6.75	4.88	2.88	3.00	3.92	3
EJ664	6.00	6.00	4.00	4.00	6.75	4.88	4.88	3.00	3.92	4
EJ884	8.00	8.00	4.00	6.00	8.75	6.75	6.88	4.00	3.92	7
EJ8104	8.00	10.00	4.00	8.00	8.75	6.88	8.75	4.00	3.92	8
EJ1084	10.00	8.00	4.00	6.00	10.75	8.75	6.88	5.00	3.92	8
EJ1264	12.00	6.00	4.00	4.00	12.75	10.75	4.88	6.00	3.92	8
EJ10125	10.00	12.00	5.00	10.00	10.75	8.88	10.75	5.00	4.92	10
EJ12105	12.00	10.00	5.00	8.00	12.75	10.75	8.88	6.00	4.92	12
EJ866	8.00	6.00	6.00	4.00	8.75	6.75	4.88	4.00	5.92	7
EJ1086	10.00	8.00	6.00	6.00	10.75	8.75	6.88	5.00	5.92	10
EJ10106	10.00	10.00	6.00	8.00	10.75	8.75	8.88	5.00	5.92	12
EJ12126	12.00	12.00	6.00	10.00	12.75	10.75	10.88	6.00	5.92	15
EJ12146	12.00	14.00	6.00	12.00	12.75	10.88	12.75	6.00	5.92	17
EJ1486	14.00	8.00	6.00	6.00	14.75	12.75	6.88	7.00	5.92	10
EJ14126	14.00	12.00	6.00	10.00	14.75	12.75	10.88	7.00	5.92	17
EJ14166	14.00	16.00	6.00	14.00	14.75	12.88	14.75	7.00	5.92	21
EJ16106	16.00	10.00	6.00	8.00	16.75	14.75	8.88	8.00	5.92	15
EJ16146	16.00	14.00	6.00	12.00	16.75	14.75	12.88	8.00	5.92	21
EJ12108	12.00	10.00	8.00	8.00	12.75	10.75	8.88	6.00	7.92	15
EJ14128	14.00	12.00	8.00	10.00	14.75	12.75	10.88	7.00	7.92	18
EJ16148	16.00	14.00	8.00	12.00	16.75	14.75	12.88	8.00	7.92	22
EJ161410	16.00	14.00	10.00	12.00	16.75	14.75	12.88	8.00	9.92	23

Technical references and DXF downloads available at www.hammg.com

All dimensions in inches unless specified otherwise

Quality Enclosures. Service Excellence.

1414 Series JIC Enclosures - NEMA 12, 13

Clamped, Lift Off Cover



**Inner
Panel
Included**



Application

- Designed for use as instrument enclosures, electric, hydraulic or pneumatic control housings, electrical junction boxes or terminal wiring enclosures.
- Provides a degree of protection from falling dirt, dust, oil and water.

Standards

- UL 508 Type 12 and 13
- CSA Type 12 and 13
- **Complies with**
 - NEMA Type 12 and 13
 - JIC EGP-1-1967 unless marked¹
 - IEC 529, IP65

Construction

- Body formed from 16 gauge or 14 gauge steel. Covers are formed from 14 gauge steel.
- Smooth, continuously welded seams without knockouts, cutouts or holes.
- Welded brackets provide for enclosure mounting.
- Lift off cover is secured with stainless steel clamps and plated steel screws and retained with a plated chain when open.
- Oil resistant gaskets are permanently secured.
- Models larger than 4" x 4" include a removable 14 gauge inner panel.
- Weldnuts are provided for mounting inner panels.
- A grounding stud is provided in the enclosure.

Finish

- Cover and enclosure are phosphatized and finished in ANSI/ASA 61 gray recoatable powder coating.
- Removable inner panel is finished in white powder coating.

Accessories

- Additional inner panels...*see page 384*
- Breather kits...*see page 374*
- Door clamping hardware...*see page 378*
- Filter fans...*see page 360-367*
- Heaters...*see page 369-371*
- Louvered ventilating plates...*see page 396*
- Terminal kit assemblies...*see page 386*
- Thermostats...*see page 374*
- Window kits...*see page 391*

1414 Series JIC Enclosures - NEMA 12, 13

Clamped, Lift Off Cover

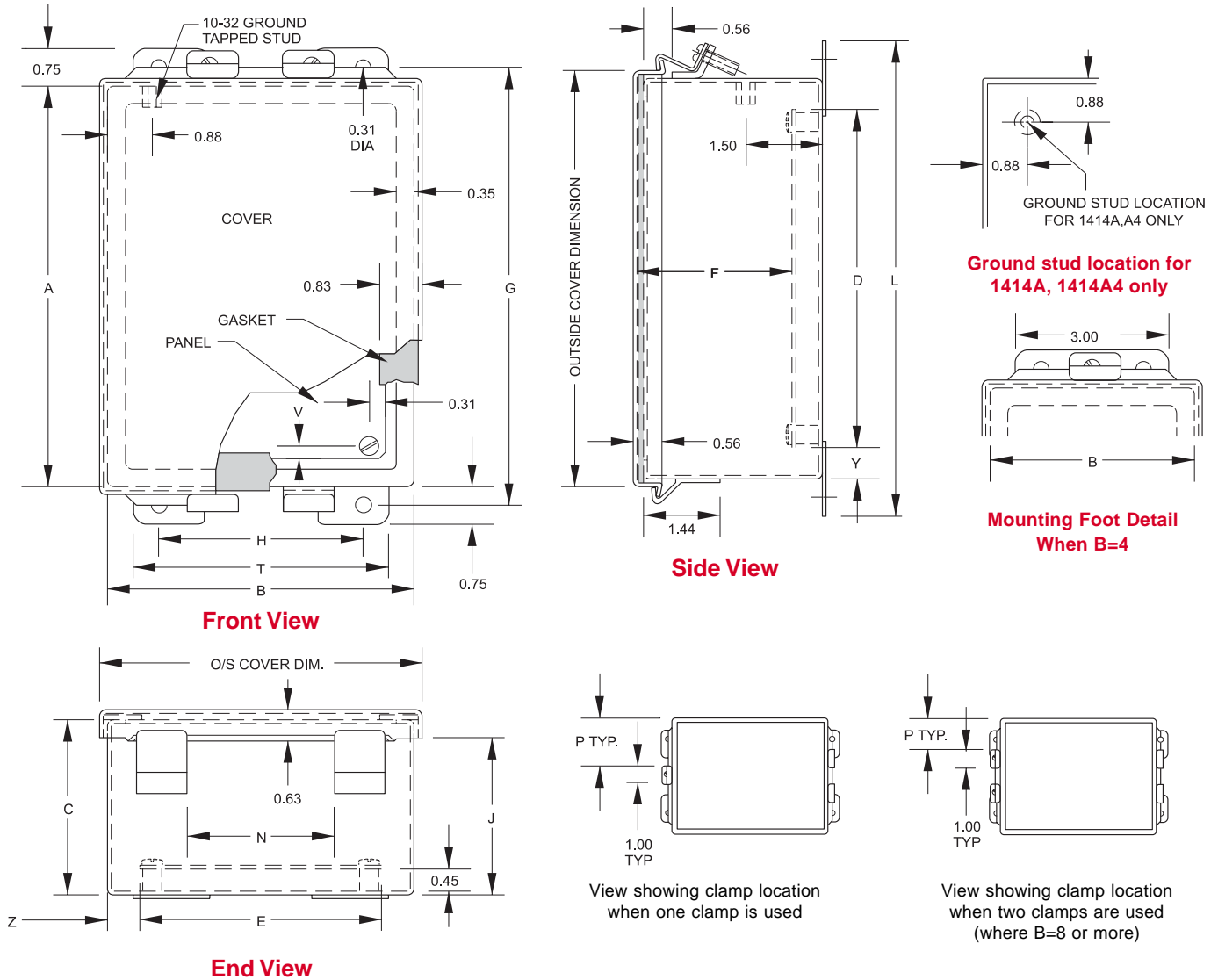

Industrial Enclosures
Junction Boxes/JIC Enclosures

Part No.	Panel Size			Centers				Cover Dimensions				Ship Wt.							
	A	B	C	D	E	F	G	H	J	L	N	P	T	V	Y	Z	Lbs.		
1414A ¹	4	4	3.0	—	—	—	4.75	2	2.64	5.5	1.31	4.31	4.31	1.5	3	—	—	2	
1414C ¹	6	4	3.0	4.88	2.88	2.51	6.75	2	2.64	7.5	1.31	6.31	4.31	1.5	3	0.31	0.56	0.56	3
1414G	8	6	3.5	6.75	4.88	3.01	8.75	4	3.14	9.5	2.88	8.31	6.31	2.5	5	0.25	0.63	0.56	7
1414A4 ¹	4	4	4.0	—	—	—	4.75	2	3.64	5.5	1.31	4.31	4.31	1.5	3	—	—	—	3
1414C4 ¹	6	4	4.0	4.88	2.88	3.51	6.75	2	3.64	7.5	1.31	6.31	4.31	1.5	3	0.31	0.56	0.56	4
1414E	6	6	4.0	4.88	4.88	3.51	6.75	4	3.64	7.5	2.88	6.31	6.31	2.5	5	0.31	0.56	0.56	5
1414I	10	8	4.0	8.75	6.88	3.51	10.75	6	3.64	11.5	4.00	10.31	8.31	1.0	7	0.25	0.63	0.56	10
1414K	12	10	5.0	10.75	8.88	4.51	12.75	8	4.64	13.5	6.00	12.31	10.31	1.0	9	0.25	0.63	0.56	13
1414M6	14	12	6.0	12.75	10.88	5.51	14.75	10	5.64	15.5	8.00	14.31	12.31	1.0	11	0.25	0.63	0.56	19
1414O6	16	14	6.0	14.75	12.88	5.51	16.75	12	5.64	17.5	10.00	16.31	14.31	1.0	13	0.25	0.63	0.56	23
1414M8	14	12	8.0	12.75	10.88	7.51	14.75	10	7.64	15.5	8.00	14.31	12.31	1.0	11	0.25	0.63	0.56	20
1414O10	16	14	10.0	14.75	12.88	9.51	16.75	12	9.64	17.5	10.00	16.31	14.31	1.0	13	0.25	0.63	0.56	25

¹ Does not meet JIC requirements

1414 N4 Series JIC Enclosures - NEMA 12, 13, 4

Clamped, Lift Off Cover

Industrial Enclosures
Junction Boxes/JIC Enclosures



**Inner
Panel
Included**



Application

- Designed for use as instrument enclosures, electric, hydraulic or pneumatic control housings, electrical junction boxes or terminal wiring enclosures.
- Provides protection where equipment may be hosed down or otherwise be very wet, or in outdoor applications for full weather protection.

Standards

- UL 508 Type 3R, 4, 12 and 13
- CSA Type 3R, 4, 12 and 13
- **Complies with**
 - NEMA Type 3R, 4, and 12
 - JIC EGP-1-1967
 - IEC 529, IP66

Construction

- Body formed from 16 or 14 gauge steel. Covers are formed from 14 gauge steel.
- Smooth, continuously welded seams without knockouts, cutouts or holes.
- Welded brackets provide for enclosure mounting.
- Lift off cover is secured with stainless steel clamps and screws.
- Oil resistant gaskets are permanently secured.
- All models larger than 4" x 4" include a removable 14 gauge inner panel.
- Weldnuts are provided for mounting inner panels.
- A grounding stud is provided in the enclosure.

Finish

- Cover and enclosure are phosphatized, primed and finished in recoatable smooth ANSI/ASA 61 gray powder coating.
- Removable inner panel is finished in white powder coating.

Accessories

- Additional inner panels...*see page 384*
- Breather kits...*see page 374*
- Door clamping hardware...*see page 378*
- Filter fans...*see page 360-367*
- Heaters...*see page 369-371*
- Louvered ventilating plates...*see page 396*
- Terminal kit assemblies...*see page 386*
- Thermostats...*see page 374*
- Window kits...*see page 391*

1414 N4 Series JIC Enclosures - NEMA 12, 13, 4

Clamped, Lift Off Cover

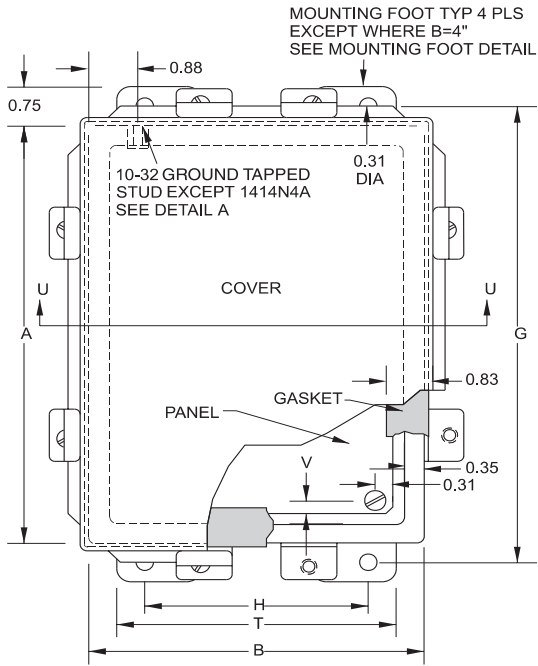

Front View

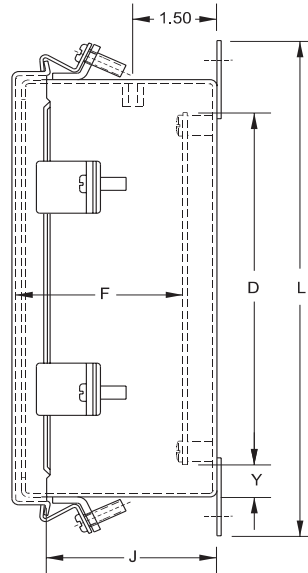

Side View

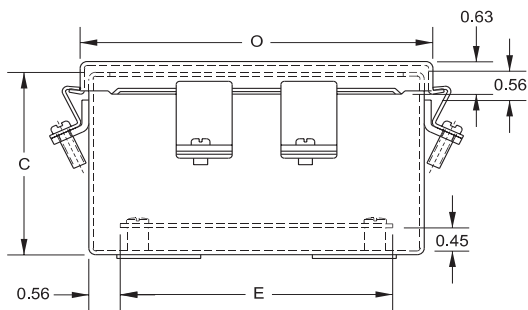

Top View

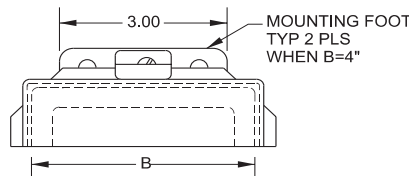

Mounting Foot Detail When B=4

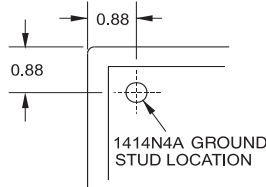

Ground stud location for 1414N4A

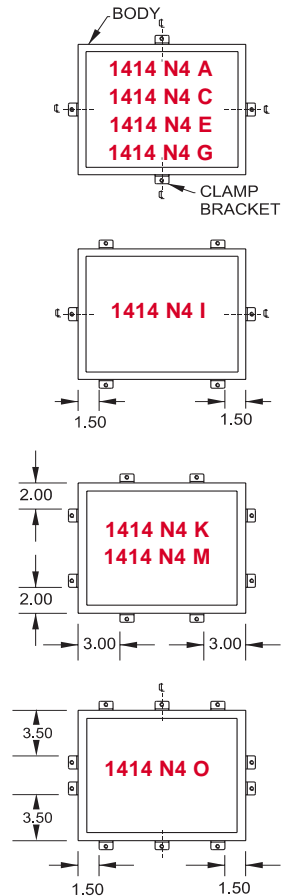

Part No.	Panel Dimensions						Centers				Cover Dimensions			Ship Wt. lbs.		
	A	B	C	D	E	F	G	H	J	L	T	V	Y			
1414N4A ¹	4	4	3.0	—	—	—	4.75	2	2.60	5.5	4.31	4.31	3	—	—	2
1414N4C	6	4	3.0	4.88	2.88	2.50	6.75	2	2.60	7.5	6.31	4.31	3	.31	.56	3
1414N4G	8	6	3.5	6.75	4.88	3.00	8.75	4	3.10	9.5	8.31	6.31	5	.25	.63	6
1414N4E	6	6	4.0	4.88	4.88	3.50	6.75	4	3.60	7.5	6.31	6.31	5	.31	.56	6
1414N4I	10	8	4.0	8.75	6.88	3.50	10.75	6	3.60	11.5	10.31	8.31	7	.25	.63	10
1414N4K	12	10	5.0	10.75	8.88	4.50	12.75	8	4.60	13.5	12.31	10.31	9	.25	.63	15
1414N4M6	14	12	6.0	12.75	10.88	5.50	14.75	10	5.60	15.5	14.31	12.31	11	.25	.63	20
1414N4O6	16	14	6.0	14.75	12.88	5.50	16.75	12	5.60	17.5	16.31	14.31	13	.25	.63	26
1414N4M8	14	12	8.0	12.75	10.88	7.50	14.75	10	7.60	15.5	14.31	12.31	11	.25	.63	22
1414N4O10	16	14	10.0	14.75	12.88	9.50	16.75	12	9.60	17.5	16.31	14.31	13	.25	.63	30

¹ Panel not included

1414 PH Series JIC Enclosures - NEMA 12, 13

Continuous Hinge, Clamped Cover

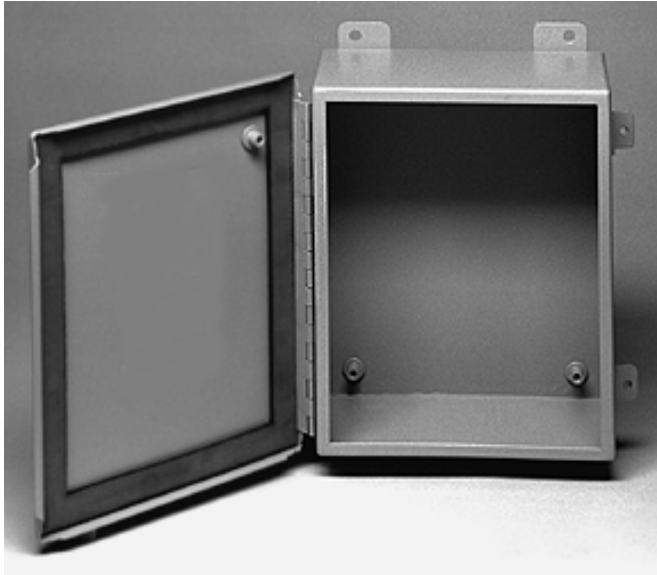

**Inner
Panel
Included**



Industrial Enclosures
Junction Boxes/JIC Enclosures

Application

- Designed for use as instrument enclosures, electric, hydraulic or pneumatic control housings, electrical junction boxes or terminal wiring enclosures.
- Provides a degree of protection from falling dirt, dust, oil and water.

Standards

- UL 508 Type 12, 13
- CSA Type 12, 13
- **Complies with**
 - NEMA Type 12 and 13
 - JIC EGP-1-1967 unless marked¹
 - IEC 529, IP65

Construction

- Body formed from 16 gauge or 14 gauge steel. Covers are formed from 14 gauge steel.
- Smooth, continuously welded seams without knockouts, cutouts or holes.
- Welded brackets provide for enclosure mounting.
- Continuously hinged cover is secured with stainless steel clamps and plated steel screws.
- Oil resistant gaskets are permanently secured.
- Models larger than 4" x 4" include a removable 14 gauge inner panel.
- Weldnuts are provided for mounting inner panels.
- A bonding stud is provided on the door and a grounding stud is provided in the enclosure.

Finish

- Cover and enclosure are phosphatized and finished in ANSI/ASA 61 gray recoatable powder coating.
- Removable inner panel is finished in white powder coating.

Accessories

- Additional inner panels...see page **384**
- Breather kits...see page **374**
- Door clamping hardware...see page **378**
- Filter fans...see page **360-367**
- Heaters...see page **369-371**
- Louvered ventilating plates...see page **396**
- Te6
- Thermostats...see page **374**
- Window kits...see page **391**

1414 PH Series JIC Enclosures - NEMA 12, 13

Continuous Hinge, Clamped Cover

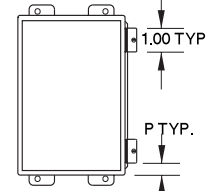
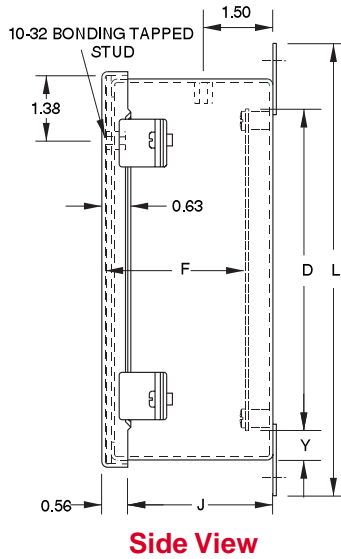
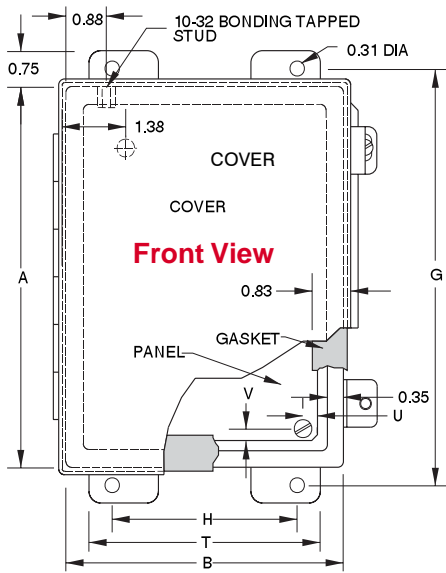

View showing clamp location when two clamps are used (where A=8 or more)

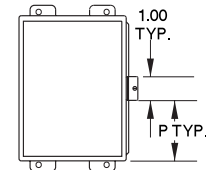

View showing clamp location when one clamp is used

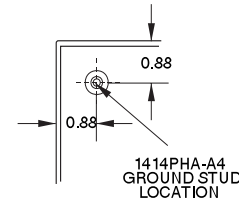
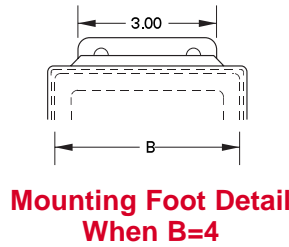
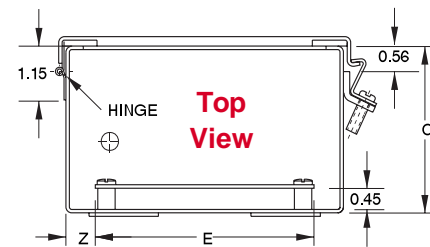

Part No.	Part No. Without Inner Panel	A	B	C	Panel Size		Centers				Cover Dimensions				Ship Wt. lbs with panel		Ship Wt. lbs with out				
Part No.	Part No. Without Inner Panel	A	B	C	D	E	F	G	H	J	L	P	T	U	V	Y	Z	panel	out		
—	1414PHA ¹	4	4	3.0	—	—	—	4.75	2	2.64	5.5	4.31	4.31	1.5	3	—	—	—	2	2	
1414PHC ¹	1414PHCLP ¹	6	4	3.0	4.88	2.88	2.51	6.75	2	2.64	7.5	6.31	4.31	2.5	3	.31	.31	.56	.56	3	2
1414PHG	1414PHGLP	8	6	3.5	6.75	4.88	3.01	8.75	4	3.14	9.5	8.31	6.31	1.0	5	.31	.25	.63	.56	6	5
1414PHRG	1414PHRGLP	6	8	3.5	4.88	6.75	3.01	6.75	6	3.14	7.5	6.31	8.31	2.5	7	.25	.31	.56	.63	6	5
—	1414PHA ¹	4	4	4.0	—	—	—	4.75	2	3.64	5.5	4.31	4.31	1.5	3	—	—	—	—	3	3
1414PHC4 ¹	1414PHC4LP ¹	6	4	4.0	4.88	2.88	3.51	6.75	2	3.64	7.5	6.31	4.31	2.5	3	.31	.31	.56	.56	4	3
1414PHE	1414PHELP	6	6	4.0	4.88	4.88	3.51	6.75	4	3.64	7.5	6.31	6.31	2.5	5	.31	.31	.56	.56	5	4
1414PHH4	1414PHH4LP	8	8	4.0	6.75	6.88	3.51	8.75	6	3.64	9.5	8.31	8.31	1.0	7	.31	.25	.63	.56	8	7
1414PHI	1414PHILP	10	8	4.0	8.75	6.88	3.51	10.75	6	3.64	11.5	10.31	8.31	1.0	7	.31	.25	.63	.56	10	8
1414PHRI	1414PHRILP	8	10	4.0	6.88	8.75	3.51	8.75	8	3.64	9.5	8.31	10.31	1.0	9	.25	.31	.56	.63	10	8
1414PHKC4	1414PHKC4LP	12	6	4.0	10.75	4.88	3.51	12.75	4	3.64	13.5	12.31	6.31	1.0	5	.31	.25	.63	.56	10	8
1414PHK	1414PHKLP	12	10	5.0	10.75	8.88	4.51	12.75	8	4.64	13.5	12.31	10.31	1.0	9	.31	.25	.63	.56	13	10
1414PHRK	1414PHRKL	10	12	5.0	8.88	10.75	4.51	10.75	10	4.64	11.5	10.31	12.31	1.0	11	.25	.31	.56	.63	13	12
1414PHG6	1414PHG6LP	8	6	6.0	6.75	4.88	5.51	8.75	4	5.64	9.5	8.31	6.31	1.0	5	.31	.25	.63	.56	8	7
1414PHI6	1414PHI6LP	10	8	6.0	8.75	6.88	5.51	10.75	6	5.64	11.5	10.31	8.31	1.0	7	.31	.25	.63	.56	12	10
1414PHJ6	1414PHJ6LP	10	10	6.0	8.75	8.88	5.51	10.75	8	5.64	11.5	10.31	10.31	1.0	9	.31	.25	.63	.56	14	12
1414PHL6	1414PHL6LP	12	12	6.0	10.75	10.88	5.51	12.75	10	5.64	13.5	12.31	12.31	1.0	11	.31	.25	.63	.56	17	15
1414PHMH6	1414PHMH6LP	14	8	6.0	12.75	6.88	5.51	14.75	6	5.64	15.5	14.31	8.31	1.0	7	.31	.25	.63	.56	12	10
1414PHM6	1414PHM6LP	14	12	6.0	12.75	10.88	5.51	14.75	10	5.64	15.5	14.31	12.31	1.0	11	.31	.25	.63	.56	19	17
1414PHRM6	1414PHRM6LP	12	14	6.0	10.88	12.75	5.51	12.75	12	5.64	13.5	12.31	14.31	1.0	13	.25	.31	.56	.63	19	17
1414PHN6	1414PHN6LP	16	10	6.0	14.75	8.88	5.51	16.75	8	5.64	17.5	16.31	10.31	1.0	9	.31	.25	.63	.56	18	15
1414PHO6	1414PHO6LP	16	14	6.0	14.75	12.88	5.51	16.75	12	5.64	17.5	16.31	14.31	1.0	13	.31	.25	.63	.56	23	21
1414PHRO6	1414PHRO6LP	14	16	6.0	12.88	14.75	5.51	14.75	14	5.64	15.5	14.31	16.31	1.0	15	.25	.31	.56	.63	23	21
1414PHK8	1414PHK8LP	12	10	8.0	10.75	8.88	7.51	12.75	8	7.64	13.5	12.31	10.31	1.0	9	.31	.25	.63	.56	18	15
1414PHM8	1414PHM8LP	14	12	8.0	12.75	10.88	7.51	14.75	10	7.64	15.5	14.31	12.31	1.0	11	.31	.25	.63	.56	20	18
1414PHO8	1414PHO8LP	16	14	8.0	14.75	12.88	7.51	16.75	12	7.64	17.5	16.31	14.31	1.0	13	.31	.25	.63	.56	25	22
1414PHO10	1414PHO10LP	16	14	10.0	14.75	12.88	9.51	16.75	12	9.64	17.5	16.31	14.31	1.0	13	.31	.25	.63	.56	26	23

¹ Does not meet JIC requirements.

1414 N4 PH Series JIC Enclosures - NEMA 12, 13, 4

Continuous Hinge, Clamped Cover



**Inner
Panel
Included**



Industrial Enclosures
Junction Boxes/JIC Enclosures

Application

- Designed for use as instrument enclosures, electric, hydraulic or pneumatic control housings, electrical junction boxes or terminal wiring enclosures.
- Provides protection where equipment may be hosed down or otherwise be very wet, or in outdoor applications for full weather protection.

Standards

- UL 508 Type 3R, 4, 12 and 13
- CSA Type 3R, 4, 12 and 13
- **Complies with**
 - NEMA Type 3R, 4, 12 and 13
 - JIC EGP-1-1967 unless marked¹
 - IEC 529, IP66

Construction

- Body formed from 16 or 14 gauge steel. Covers are formed from 14 gauge steel.
- Smooth, continuously welded seams without knockouts, cutouts or holes.
- Welded brackets provide for enclosure mounting.
- Continuous hinged cover is secured with stainless steel clamps and screws.
- Stainless steel continuous hinge on door may be removed by pulling the stainless steel hinge pin.
- Oil resistant gaskets are permanently secured.
- All models larger than 4" x 4" include a removable 14 gauge inner panel.
- Weldnuts are provided for mounting inner panels.
- A bonding stud is provided on the door and a grounding stud is provided in the enclosure.

Finish

- Cover and enclosure are phosphatized, primed and finished in recoatable smooth ANSI/ASA 61 gray powder coating.
- Removable inner panel is finished in white powder coating.

Accessories

- Additional inner panels...*see page 384*
- Breather kits...*see page 374*
- Door clamping hardware...*see page 378*
- Filter fans...*see page 360-367*
- Heaters...*see page 369-371*
- Louvered ventilating plates...*see page 396*
- Terminal kit assemblies...*see page 386*
- Thermostats...*see page 374*
- Window kits...*see page 391*

1414 N4 PH Series JIC Enclosures - NEMA 12, 13, 4

Continuous Hinge, Clamped Cover

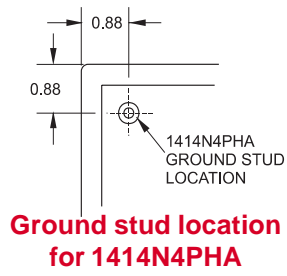
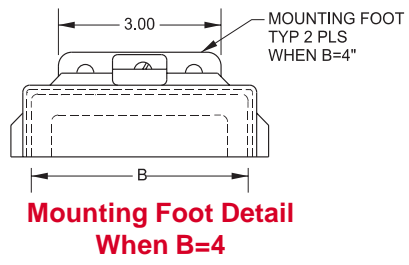
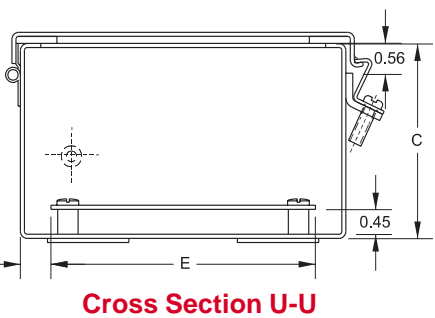
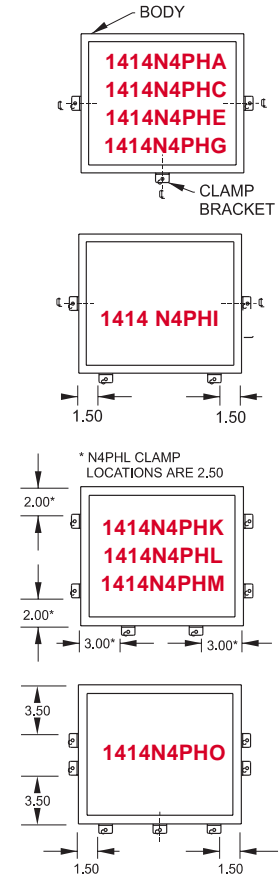
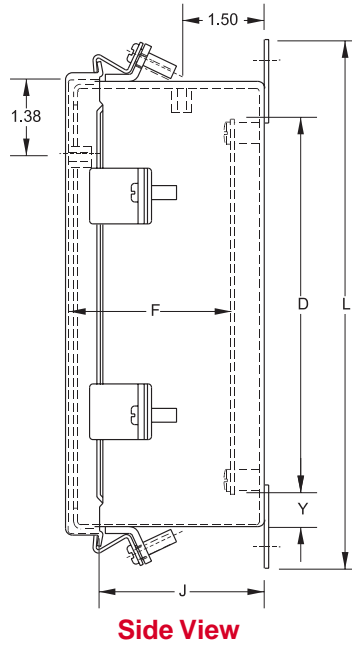
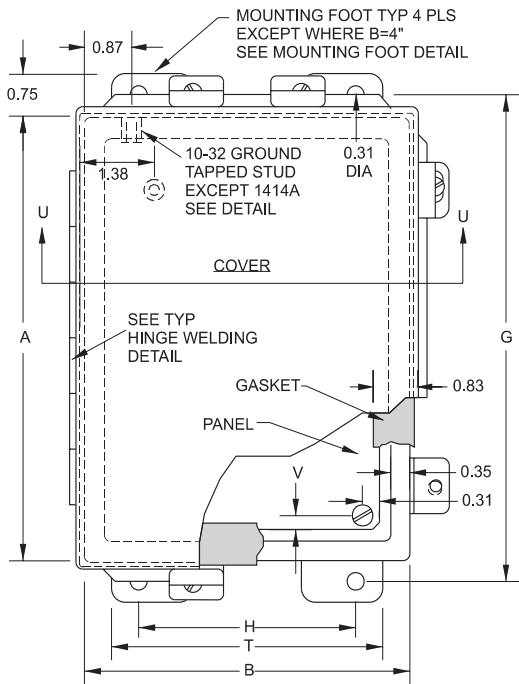

Part No.	Part No. without Inner Panel	Panel Dimensions					Centers					Cover Dimensions			Ship Wt. (lbs.) with with-panel out			
		A	B	C	D	E	F	G	H	J	L	T	V	Y	panel out			
—	1414N4PHA ¹	4	4	3.0	—	—	—	4.75	2	2.6	5.5	4.31	4.31	3	—	—	2	1
1414N4PHC ¹	1414N4PHCLP ¹	6	4	3.0	4.88	2.88	2.5	6.75	2	2.6	7.5	6.31	4.31	3	.31	.56	3	2
1414N4PHG	1414N4PHGLP	8	6	3.5	6.75	4.88	3.0	8.75	4	3.1	9.5	8.31	6.31	5	.25	.63	6	5
1414N4PHE	1414N4PHELP	6	6	4.0	4.88	4.88	3.5	6.75	4	3.6	7.5	6.31	6.31	5	.31	.56	5	4
1414N4PHI	1414N4PHILP	10	8	4.0	8.75	6.88	3.5	10.75	6	3.6	11.5	10.31	8.31	7	.25	.63	10	9
1414N4PHI6	1414N4PHI6LP	10	8	6.0	8.75	6.88	5.5	10.75	6	5.6	11.5	10.31	8.31	7	.25	.63	12	11
1414N4PHK	1414N4PHKLP	12	10	5.0	10.75	8.88	4.5	12.75	8	4.6	13.5	12.31	10.31	9	.25	.63	15	14
1414N4PHL6	1414N4PHL6LP	12	12	6.0	10.75	10.88	5.5	12.75	10	5.6	13.5	12.31	12.31	11	.25	.63	25	24
1414N4PHM6	1414N4PHM6LP	14	12	6.0	12.75	10.88	5.5	14.75	10	5.6	15.5	14.31	12.31	11	.25	.63	21	20
1414N4PHO6	1414N4PHO6LP	16	14	6.0	14.75	12.88	5.5	16.75	12	5.6	17.5	16.31	14.31	13	.25	.63	26	24
1414N4PHM8	1414N4PHM8LP	14	12	8.0	12.75	10.88	7.5	14.75	10	7.6	15.5	14.31	12.31	11	.25	.63	22	20
1414N4PHO10	1414N4PHO10LP	16	14	10.0	14.75	12.88	9.5	16.75	12	9.6	17.5	16.31	14.31	13	.25	.63	28	26

¹ Does not meet JIC requirements

1414 SC Series JIC Enclosures - NEMA 12, 13

Lift Off, Screw Cover

Industrial Enclosures
Junction Boxes/JIC Enclosures



**Inner
Panel
Included**



Application

- Designed for use as instrument enclosures, electric, hydraulic or pneumatic control housings, electrical junction boxes or terminal wiring enclosures.
- Provides a degree of protection from falling dirt, dust, oil and water.

Standards

- UL 508 Type 12 and 13
- CSA Type 12 and 13
- **Complies with**
 - NEMA Type 12 and 13
 - JIC EGP-1-1967 unless marked¹
 - IEC 529, IP65

Construction

- Body formed from 16 gauge or 14 gauge steel. Covers are formed from 14 gauge steel.
- Smooth, continuously welded seams without knockouts, cutouts or holes.
- Welded brackets provide for enclosure mounting.
- Cover is secured with captive, plated steel screws, threaded into sealed wells.
- Oil resistant gaskets are permanently secured.
- Models larger than 4" x 4" include a removable 14 gauge inner panel.
- Weldnuts are provided for mounting inner panels.
- A grounding stud is provided in the enclosure.

Finish

- Cover and enclosure are phosphatized and finished in ANSI/ASA 61 gray recoatable powder coating.
- Removable inner panel is finished in white powder coating.

Accessories

- Additional inner panels...see page **384**
- Breather kits...see page **374**
- Filter fans...see page **360-367**
- Heaters...see page **369-371**
- Louvered ventilating plates...see page **396**
- Terminal kit assemblies...see page **386**
- Thermostats...see page **374**
- Window kits...see page **391**

1436/1438 Series Junction Boxes - NEMA 12, 13

Lift Off, Screw Cover



1436 Standard Depth



1438 Extra Depth

Industrial Enclosures
Junction Boxes

Application

- Designed for use as instrument enclosures, electrical junction boxes or terminal wiring enclosures.
- Provides a degree of protection from falling dirt, dust, oil and water.

Standards

- UL 508 Type 12 and 13
- CSA Type 12 and 13
- Complies with
 - NEMA Type 12 and 13
 - IEC 529, IP65

Construction

- Formed from 14 gauge steel.
- Smooth, continuously welded seams without knockouts, cutouts or holes.
- Welded brackets provide for enclosure mounting.
- Lift off cover is secured with captive, plated steel screws, and supported on internal hinges except as noted on charts at bottom and right.
- Cover screws fasten into threaded, sealed wells.
- Oil resistant gaskets are permanently secured and mechanically retained.
- A grounding stud is provided in the enclosure.

Finish

- Cover and enclosure are phosphatized and finished in ANSI/ASA 61 gray recoatable powder coating.

Standard Depth Series (1436)

Part No.	Centers					Overall Dimensions		Ship Wt. lbs
	A	B	C	D	E	L	W	
1436A ¹	3.50	3.25	2.75	2.38	4.00	4.50	3.56	2
1436B ¹	5.75	3.25	2.75	2.38	6.25	6.75	3.56	2
1436C ¹	8.00	3.25	2.75	2.38	8.50	9.00	3.56	3
1436D ¹	10.25	3.25	2.75	2.38	10.75	11.25	3.56	4
1436F	7.25	6.25	3.00	5.38	7.75	8.25	6.56	5
1436H	9.50	6.25	3.00	5.38	10.00	10.50	6.56	5
1436K	9.50	8.50	3.00	7.63	10.00	10.50	8.81	7
1436O	11.75	8.50	3.00	7.63	12.25	12.75	8.81	8
1436S	11.75	10.75	3.00	9.88	12.25	12.75	11.06	9
1436V	14.00	10.75	3.00	9.88	14.50	15.00	11.06	11
1436X	14.00	13.00	3.00	12.13	14.50	15.00	13.31	12
1436-30	16.25	13.00	3.00	12.13	16.75	17.25	13.31	14
1436-36	16.25	15.25	3.00	14.38	16.75	17.25	15.56	16
1436-42	18.50	15.25	3.00	14.38	19.00	19.50	15.56	18

¹ Not hinged

1436/1438 Series Junction Boxes - NEMA 12, 13

Lift Off, Screw Cover

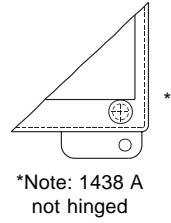
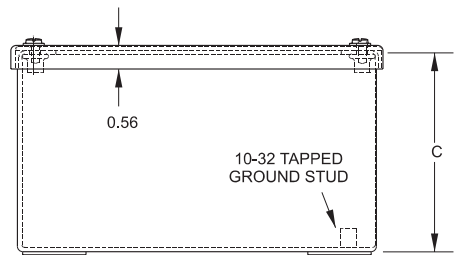
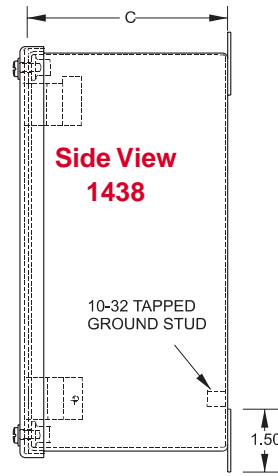
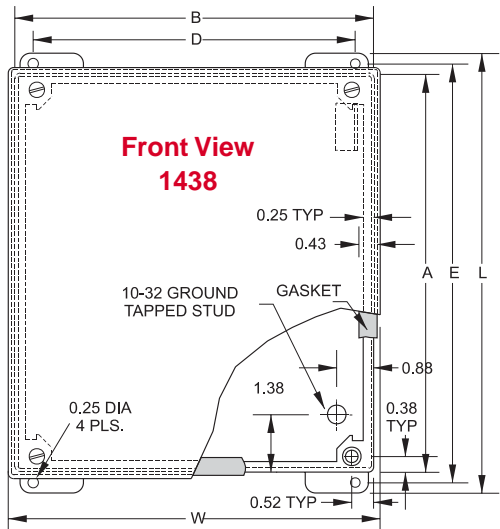
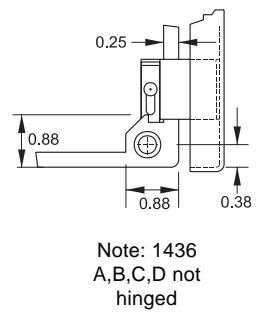
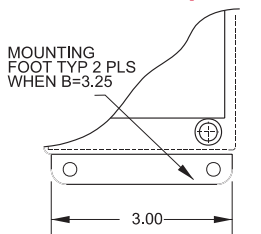
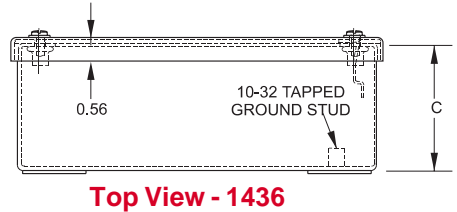
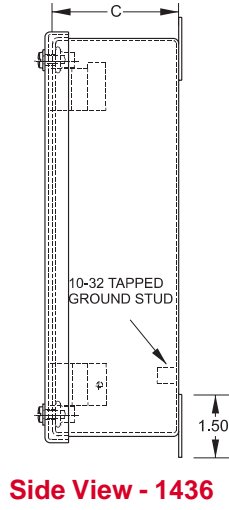
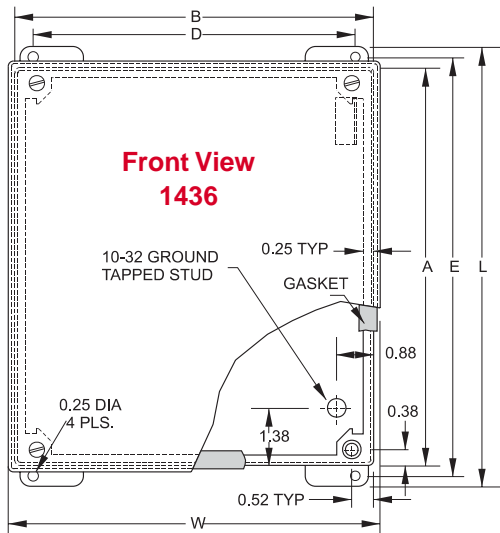

Extra Deep Series (1438)

Part No.	Centers					Overall Dimensions		Ship Wt. lbs
	A	B	C	D	E	L	W	
1438A ¹	4.00	4.00	4.75	3.13	4.50	5.00	4.31	3
1438B	6.00	4.00	4.75	3.13	6.50	7.00	4.31	4
1438C	8.00	4.00	4.75	3.13	8.50	9.00	4.31	5
1438D	10.00	4.00	4.75	3.13	10.50	11.00	4.31	5
1438F	7.25	6.25	4.75	5.38	7.75	8.25	6.56	5
1438H	9.50	6.25	4.75	5.38	10.00	10.50	6.56	5
1438K	9.50	8.50	4.75	7.63	10.00	10.50	8.81	7
1438O	11.75	8.50	4.75	7.63	12.25	12.75	8.81	8
1438S	11.75	10.75	4.75	9.88	12.25	12.75	11.06	9
1438V	14.00	10.75	4.75	9.88	14.50	15.00	11.06	11
1438X	14.00	13.00	4.75	12.13	14.50	15.00	13.31	12
1438-30	16.25	13.00	4.75	12.13	16.75	17.25	13.31	14
1438-36	16.25	15.25	4.75	14.38	16.75	17.25	15.56	16
1438-42	18.50	15.25	4.75	14.38	19.00	19.50	15.56	18

¹ Not hinged

1418J Series - NEMA 12

Large JIC Enclosures

Industrial Enclosures
Junction Boxes



**Inner
Panel
Included**



Application

- Designed to house electrical, electronic, hydraulic or pneumatic controls and instruments.
- Provides a degree of protection from falling dirt, dust, oil and water.

Standards

- UL 508 Type 12
- **Complies with**
 - NEMA Type 12
 - JIC EGP-1-1967 unless marked¹
 - IEC 529, IP65

Construction

- Formed from 14 gauge steel.
- Smooth, continuously welded seams without knockouts, cutouts or holes.
- Door and body stiffeners are provided in the larger enclosures for extra rigidity.
- Welded brackets provide for enclosure mounting.
- Continuously hinged cover is secured with stainless steel screws, threaded into sealed wells.
- Oil resistant gaskets are permanently secured and mechanically retained.
- A removable 12 gauge inner panel is included.
- Collar studs are provided for mounting inner panels.
- A grounding stud is provided in the enclosure and a bonding stud is provided on the door.
- A literature pocket is provided for the inside of the door.

Finish

- Cover and enclosure are phosphatized and finished in ANSI/ASA 61 gray recoatable powder coating.
- Removable inner panel is finished in white powder coating.

Accessories

- Additional inner panels...see page **384**
- Blowers...see page **359**
- Breather kits...see page **374**
- Filter fans...see page **360-367**
- Heaters...see page **369-371**
- Louvered ventilating plates...see page **396**
- Terminal kit assemblies...see page **386**
- Thermostats...see page **374**
- Window kits...see page **391**

1418J Series - NEMA 12

Large JIC Enclosures

Industrial Enclosures
Junction Boxes/JIC Enclosures

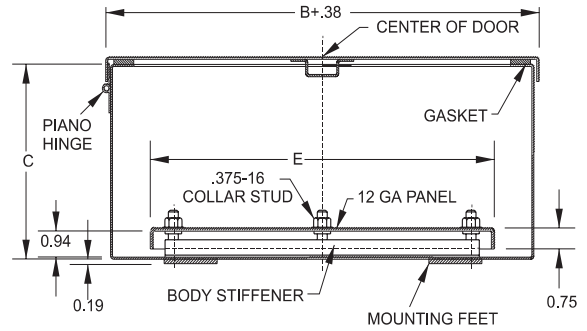
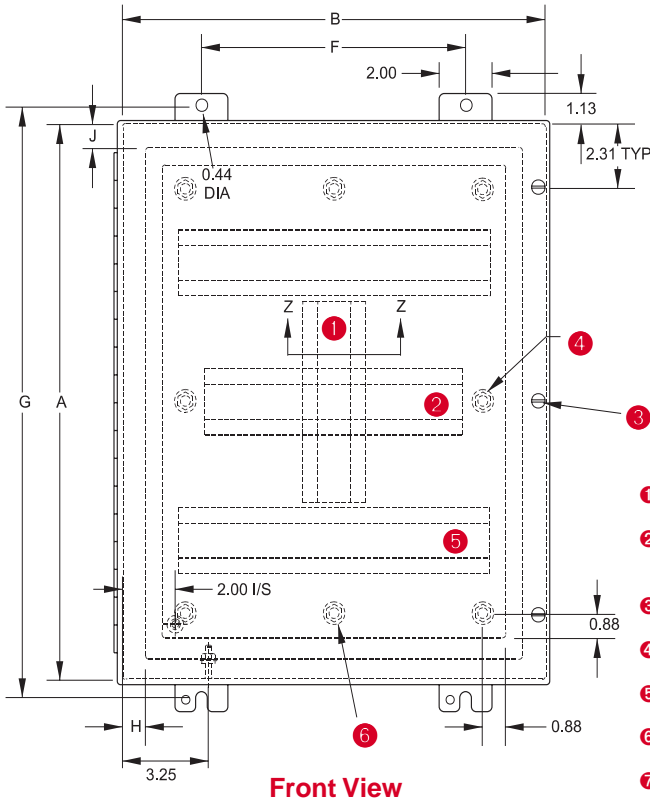

Top View

- 1 Vertical body stiffener req'd on M only
- 2 Omit if center body stiffener if A is less than 41"
- 3 Omit if A is less than 31"
- 4 Omit 2 center studs if A is less than 31"
- 5 Omit body stiffeners if B is less than 29"
- 6 Omit 2 middle studs if B is less than 31"
- 7 Omit door stiffener if A or B is 24" or less

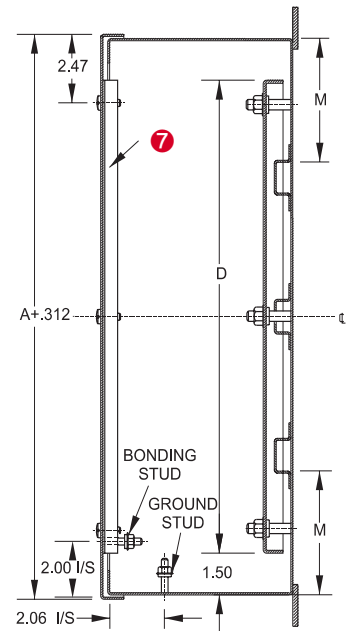

Side View

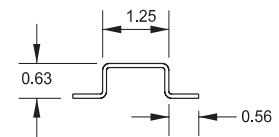

Section Z-Z

When A=	M=
30	7.00
36	9.00
42	9.88
48	11.38

Part No.	Panel Dimensions						Centers			Ship Wt. lbs
	A	B	C	D	E	F	G	H	J	
1418JB7	16	12	7	13	9	6	17.25	0.88	0.50	30
1418JC7	20	16	7	17	13	10	21.25	0.88	0.88	38
1418JD7	20	20	7	17	17	14	21.25	0.88	0.50	45
1418JE7	24	20	7	21	17	14	25.25	0.88	0.50	54
1418JJ7	24	24	7	21	21	18	25.25	0.88	0.50	63
1418JF7	30	20	7	27	17	14	31.25	0.88	0.50	70
1418JK7	30	24	7	27	21	18	31.25	0.88	0.50	78
1418JL7	36	24	7	33	21	18	37.25	0.88	0.50	90
1418JC9	20	16	9	17	13	10	21.25	0.88	0.50	42
1418JD9	20	20	9	17	17	14	21.25	0.88	0.50	45
1418JE9	24	20	9	21	17	14	25.25	0.88	0.50	60
1418JJ9	24	24	9	21	21	18	25.25	0.88	0.50	67
1418JK9	30	24	9	27	21	18	31.25	0.88	0.50	85
1418JF9	30	20	9	27	17	14	31.25	0.88	0.50	70
1418JM9	36	30	9	33	27	24	37.25	1.38	1.38	120
1418JL9	36	24	9	33	21	18	37.25	0.88	0.50	100
1418JO9 ¹	42	30	9	39	27	24	43.25	1.38	1.38	137
1418JP9 ¹	42	36	9	39	33	30	43.25	1.38	1.38	165
1418JJ11	24	24	11	21	21	18	25.25	0.88	0.50	73
1418JL11	36	24	11	33	21	18	37.25	0.88	0.50	107
1418JS11 ¹	48	36	11	45	33	30	49.25	1.38	1.38	187
1418JK13	30	24	13	27	21	18	31.25	0.88	0.50	94
1418JM13	36	30	13	33	27	24	37.25	1.38	1.38	131

¹ Does not meet JIC requirements

Eclipse Series - NEMA 4, 12

Single Door Enclosures with Gland Plate



Single Door with quarter turns



Single Door with 3 point latching handle

Order Panel Separately

Now with Gland Plate



Industrial Enclosures
Wallmount Enclosures

Application

- Designed to enclose electrical and/or electronic equipment and protect against harsh, industrial environments for wallmount applications
- Impressive styling features like hidden hinges, attractive latching systems make the Eclipse a suitable addition to any high-tech equipment installation.
- For high temperature applications, a gasket retainer may be required, please refer to factory.

Standards

- UL 508 Type 12, 4
- CSA Type 12, 4
- **Complies with**
 - NEMA Type 12 and 4
 - IEC 529, IP65

Construction

- Formed 14 or 16 gauge steel.
- Smooth, continuously welded seams ground smooth.
- Door stiffeners are provided where required for increased strength and rigidity - designed to also permit additional mounting options.
- Formed lip on enclosure to exclude flowing liquids and contaminants.
- Door latches feature the added safety of quarter turn slot requiring use of tool for opening.
- Doors may be easily removed for modifications and are interchangeable.
- Oil resistant gaskets are permanently secured.
- Collar studs provided for mounting inner panel.
- Includes hardware kit with panel mounting nuts and sealing washers for wall mounting holes.
- Bonding stud provided on door and grounding stud installed in enclosure.
- Quarter turn latches formed from mild steel (diecast key lockable handle with black epoxy finish on 3 point latch).
- Formed steel hinge with stainless steel hinge pins.
- Removable steel gland plate covers cutout in bottom allowing for easy cable entry preparation.

Finish

- Cover and enclosure are finished in recoatable textured RAL 7032 beige (CG1) powder coating.

Accessories

- Air conditioners...see page **348-357**
- Blowers...see page **359**
- Breather kits...see page **374**
- DIN rails...see page **35**
- DIN rail mounting kit...see page **35**
- Door stop kit...see page **393**
- Filter fans...see page **360-367**
- Heaters...see page **369-371**
- Handles...see page **36**
- Inner panel...see page **34**
- Quarter turn inserts and keys...see page **36**
- Literature pocket...see page **397**
- Mounting foot kit...see page **36**
- Swing frame...see page **35**
- Swing panel...see page **34**
- Replacement hinge pins...see page **34**
- Replacement quarter turn assemblies...see page **36**
- Thermostats...see page **374**
- Touch up paint...see page **396**
- UL/CSA approved hardware kit...see page **382**
- Padlock Adapter (EPA)...see page **382**

Eclipse Series - NEMA 4, 12 Single Door Enclosures with Gland Plate

Industrial Enclosures
Wallmount Enclosures

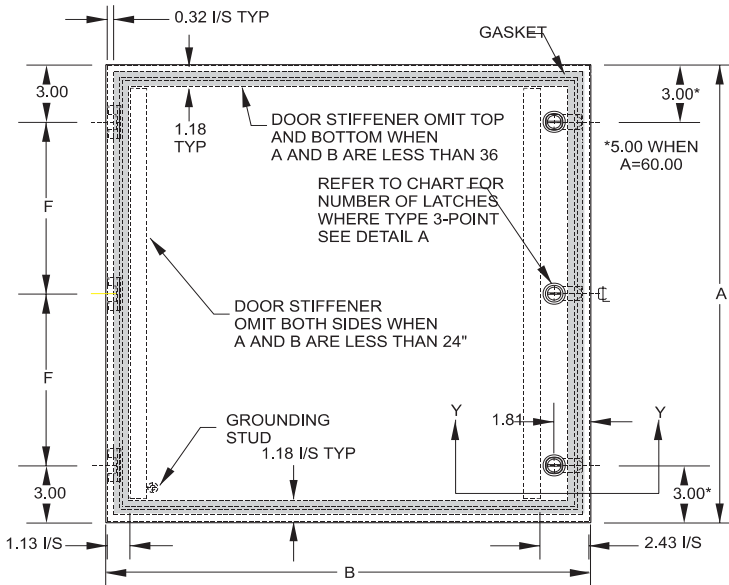

Front View

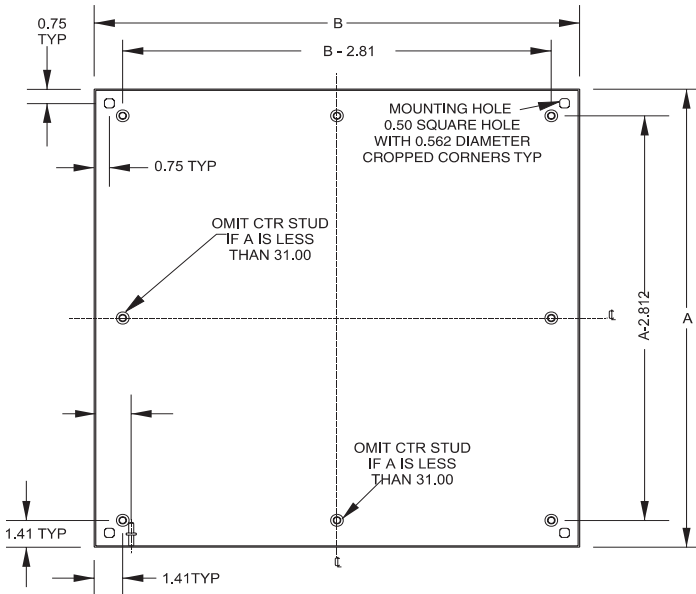

Front Section

(Door and Body Flange removed)

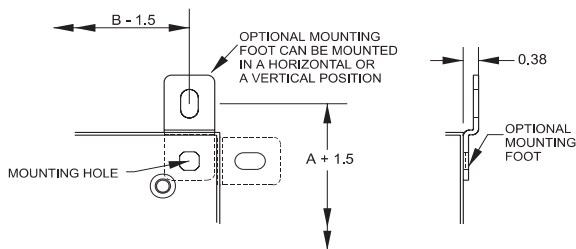

Mounting Detail

Door & Body Flange Removed

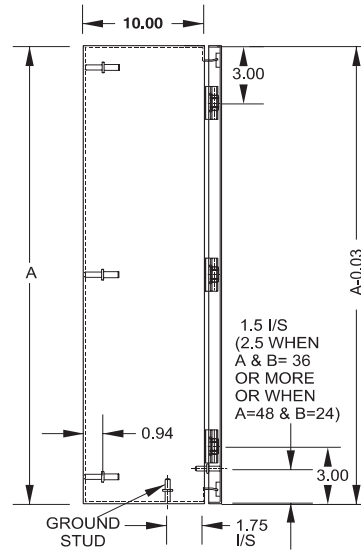

Side View

Hinge Side

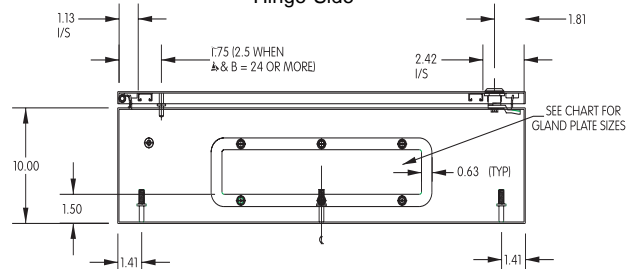

End View with Gland Plate

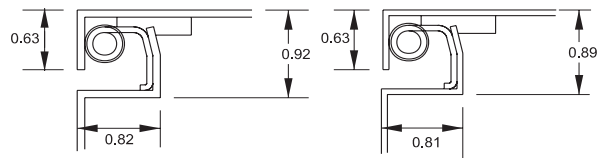

Cross Section of 14 Gauge Body & Door

Cross Section of 16 Gauge Body & Door

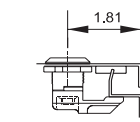

Quarter Turn Lock Section Y-Y

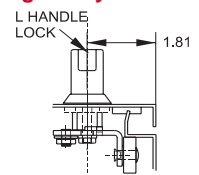

L Handle Lock Section X-X

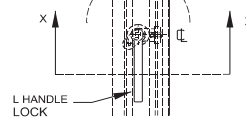

Detail A

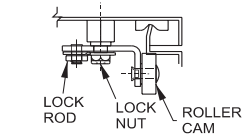

Cross Section Through End View

Door Cam Typ 2 pls when L handle is used

Refer to part number and dimension chart on previous page

Technical references and DXF downloads available at www.hammmfg.com

All dimensions in inches unless specified otherwise

Eclipse Series - NEMA 4, 12

Single Door Enclosures with Gland Plate

Part No.	Overall Dimensions			Door/Body Gauge	Latches		Opt. Panel Part No.	Panel Size		Gland Plate Opening	# Hinges	Ship Wt.	
	A	B	C		Qty	Type		D	E			F	Lbs.
EN4SD12126CG	12	12	6	16	1	Qtr Turn	EP1212	10.2	10.2	5.06 x 1.5	2	6	12
EN4SD16126CG	16	12	6	16	1	Qtr Turn	EP1612	14.2	10.2	5.06 x 1.5	2	10	16
EN4SD16166CG	16	16	6	16	1	Qtr Turn	EP1616	14.2	14.2	11.75 x 2.31	2	10	19
EN4SD16206CG	16	20	6	16	1	Qtr Turn	EP1620	14.2	18.2	11.75 x 2.31	2	10	22
EN4SD20166CG	20	16	6	16	1	Qtr Turn	EP2016	18.2	14.2	11.75 x 2.31	2	14	22
EN4SD20206CG	20	20	6	16	1	Qtr Turn	EP2020	18.2	18.2	11.75 x 2.31	2	14	26
EN4SD24166CG	24	16	6	16	1	Qtr Turn	EP2416	22.2	14.2	11.75 x 2.31	2	18	26
EN4SD24206CG	24	20	6	16	1	Qtr Turn	EP2420	22.2	18.2	11.75 x 2.31	2	18	30
EN4SD24246CG	24	24	6	14	2	Qtr Turn	EP2424	22.2	22.2	11.75 x 2.31	2	18	37
EN4SD16128CG	16	12	8	16	1	Qtr Turn	EP1612	14.2	10.2	5.06 x 1.5	2	10	16
EN4SD16168CG	16	16	8	16	1	Qtr Turn	EP1616	14.2	14.2	12.13 x 4.63	2	10	21
EN4SD16208CG	16	20	8	16	1	Qtr Turn	EP1620	14.2	18.2	12.13 x 4.63	2	10	25
EN4SD20168CG	20	16	8	16	1	Qtr Turn	EP2016	18.2	14.2	12.13 x 4.63	2	14	25
EN4SD20208CG	20	20	8	16	1	Qtr Turn	EP2020	18.2	18.2	12.13 x 4.63	2	14	28
EN4SD20248CG	20	24	8	16	1	Qtr Turn	EP2024	18.2	22.2	19.63 x 4.63	2	14	32
EN4SD24168CG	24	16	8	16	1	Qtr Turn	EP2416	22.2	14.2	12.13 x 4.63	2	18	26
EN4SD24208CG	24	20	8	16	1	Qtr Turn	EP2420	22.2	18.2	12.13 x 4.63	2	18	32
EN4SD24248CG	24	24	8	14	2	Qtr Turn	EP2424	22.2	22.2	19.63 x 4.63	2	18	40
EN4SD24308CG	24	30	8	14	2	Qtr Turn	EP2430	22.2	28.2	19.63 x 4.63	2	18	48
EN4SD30208CG	30	20	8	14	2	Qtr Turn	EP3020	28.2	18.2	12.63 x 4.63	3	12	42
EN4SD30248CG	30	24	8	14	2	Qtr Turn	EP3024	28.2	22.2	19.63 x 4.63	3	12	46
EN4SD30308CG	30	30	8	14	2	Qtr Turn	EP3030	28.2	28.2	19.63 x 4.63	3	12	67
EN4SD36248CG	36	24	8	14	2	Qtr Turn	EP3624	34.2	22.2	19.63 x 4.63	3	15	55
EN4SD36308CG	36	30	8	14	2	Qtr Turn	EP3630	34.2	28.2	19.63 x 4.63	3	15	77
EN4SD36368CG	36	36	8	14	2	Qtr Turn	EP3636	34.2	34.2	19.63 x 4.63	3	15	94
EN4SD161210CG	16	12	10	16	1	Qtr. Turn	EP1612	14.2	10.2	5.06 x 1.5	2	10	18
EN4SD161610CG	16	16	10	16	1	Qtr. Turn	EP1616	14.2	14.2	11.75 x 2.31	2	10	23
EN4SD162010CG	16	20	10	16	1	Qtr. Turn	EP1620	14.2	18.2	12.13 x 4.63	2	10	28
EN4SD201610CG	20	16	10	16	1	Qtr. Turn	EP2016	18.2	14.2	11.75 x 2.31	2	14	28
EN4SD202010CG	20	20	10	16	1	Qtr. Turn	EP2020	18.2	18.2	12.13 x 4.63	2	14	31
EN4SD202410CG	20	24	10	16	1	Qtr. Turn	EP2024	18.2	22.2	19.63 x 4.63	2	14	36
EN4SD241610CG	24	16	10	16	1	Qtr. Turn	EP2416	22.2	14.2	11.75 x 2.31	2	18	30
EN4SD242010CG	24	20	10	16	1	Qtr. Turn	EP2420	22.2	18.2	12.13 x 4.63	2	18	36
EN4SD242410CG	24	24	10	14	2	Qtr. Turn	EP2424	22.2	22.2	19.63 x 4.63	2	18	45
EN4SD243010CG	24	30	10	14	2	Qtr. Turn	EP2430	22.2	28.2	19.63 x 4.63	2	18	53
EN4SD302010CG	30	20	10	14	2	Qtr. Turn	EP3020	28.2	18.2	12.13 x 4.63	3	12	47
EN4SD302410CG	30	24	10	14	2	Qtr. Turn	EP3024	28.2	22.2	19.63 x 4.63	3	12	53
EN4SD303010CG	30	30	10	14	2	Qtr. Turn	EP3030	28.2	28.2	19.63 x 4.63	3	12	75
EN4SD362410CG	36	24	10	14	2	Qtr. Turn	EP3624	34.2	22.2	19.63 x 4.63	3	15	70
EN4SD363010CG	36	30	10	14	2	Qtr. Turn	EP3630	34.2	28.2	19.63 x 4.63	3	15	84
EN4SD363610CG	36	36	10	14	2	Qtr. Turn	EP3636	34.2	34.2	19.63 x 4.63	3	15	100
EN4SD423610CG	42	36	10	14	1	3-point	EP4236	40.2	34.2	19.63 x 4.63	4	12	117
EN4SD482410CG	48	24	10	14	1	3-point	EP4824	46.2	22.2	19.63 x 4.63	4	14	95
EN4SD483610CG	48	36	10	14	1	3-point	EP4836	46.2	34.2	19.63 x 4.63	4	14	125
EN4SD603610CG	60	36	10	14	1	3-point	EP6036	58.2	34.2	19.63 x 4.63	4	18	150
EN4SD202012CG	20	20	12	16	1	Qtr Turn	EP2020	18.2	18.2	12.13 x 4.63	2	14	34
EN4SD242012CG	24	20	12	16	1	Qtr Turn	EP2420	22.2	18.2	12.13 x 4.63	2	18	38
EN4SD242412CG	24	24	12	14	2	Qtr Turn	EP2424	22.2	22.2	19.63 x 4.63	2	18	47
EN4SD302412CG	30	24	12	14	2	Qtr Turn	EP3024	28.2	22.2	19.63 x 4.63	3	12	57
EN4SD303012CG	30	30	12	14	2	Qtr Turn	EP3030	28.2	28.2	19.63 x 4.63	3	12	80
EN4SD362412CG	36	24	12	14	2	Qtr Turn	EP3624	34.2	22.2	19.63 x 4.63	3	15	62
EN4SD363012CG	36	30	12	14	2	Qtr Turn	EP3630	34.2	28.2	19.63 x 4.63	3	15	91

Technical references and DXF downloads available at www.hammg.com

All dimensions in inches unless specified otherwise

Eclipse Series - NEMA 4, 12

Single Door Enclosures with Gland Plate

Continued from previous page.

Part No.	Overall Dimensions			Door/Body Gauge	Latches		Opt. Panel Part No.	Panel Size		Gland Plate Opening	# Hinges	Ship Wt.	
	A	B	C		Qty	Type		D	E			F	Lbs.
EN4SD363612CG	36	36	12	14	2	Qtr Turn	EP3636	34.2	34.2	19.63 x 4.63	3	15	104
EN4SD423612CG	42	36	12	14	1	3-point	EP4236	40.2	34.2	19.63 x 4.63	4	12	121
EN4SD482412CG	48	24	12	14	1	3-point	EP4824	46.2	22.2	19.63 x 4.63	4	14	98
EN4SD483612CG	48	36	12	14	1	3-point	EP4836	46.2	34.2	19.63 x 4.63	4	14	148
EN4SD603612CG	60	36	12	14	1	3-point	EP6036	58.2	34.2	19.63 x 4.63	4	18	165
EN4SD242416CG	24	24	16	14	2	Qtr Turn	EP2424	22.2	22.2	19.63 x 4.63	2	18	66
EN4SD363016CG	36	30	16	14	2	Qtr Turn	EP3630	34.2	28.2	19.63 x 4.63	3	15	102
EN4SD483616CG	48	36	16	14	1	3-point	EP4836	46.2	34.2	19.63 x 4.63	4	14	148
EN4SD242420CG	24	24	20	14	2	Qtr Turn	EP2424	22.2	22.2	19.63 x 4.63	2	18	70
EN4SD302420CG	30	24	20	14	2	Qtr Turn	EP3024	28.2	22.2	19.63 x 4.63	3	12	82
EN4SD363020CG	36	30	20	14	2	Qtr Turn	EP3630	34.2	28.2	19.63 x 4.63	3	15	117

Refer to drawing on following page
* Does not meet Nema 4 requirements

Industrial Enclosures
Wallmount Enclosures

Optional Accessories

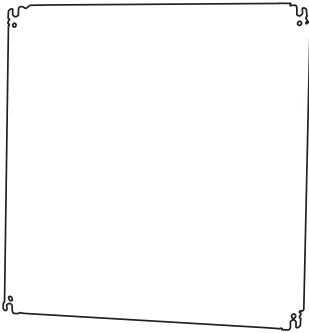

Inner panel...see page 34

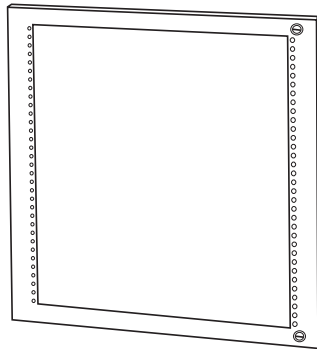

Swing frame...see page 35

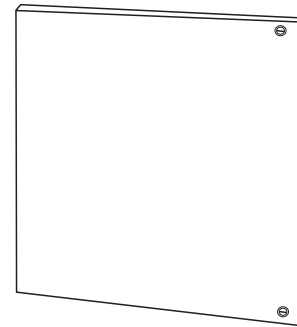

Swing panel...see page 34

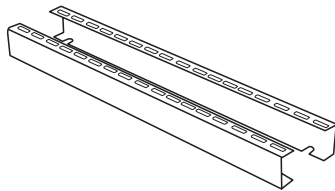

DIN rail mounting kit...see page 35

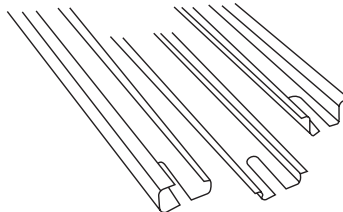

DIN rails...see page 35



Handles...see page 36

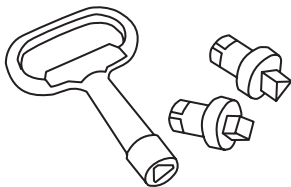

Quarter turn inserts and keys...see page 36

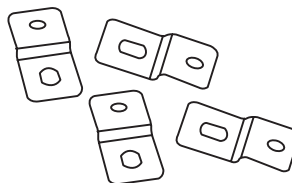

Mounting foot kit...see page 36

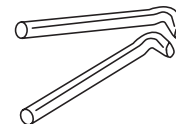

Replacement hinge pins...see page 34

Eclipse Series - NEMA 4, 12

Single Door Enclosures



Single Door with quarter turns



Single Door with 3 point latching handle

Order Panel Separately



Industrial Enclosures
Wallmount Enclosures

Application

- Designed to enclose electrical and/or electronic equipment and protect against harsh, industrial environments for wallmount applications.
- Impressive styling features like hidden hinges, attractive latching systems make the Eclipse a suitable addition to any high-tech equipment installation.
- A wide range of sizes and practical accessories make this product line a complete package.
- For high temperature applications, a gasket retainer may be required, please refer to factory.

Standards

- UL 508 Type 3R, 4, 12 and 13
- CSA Type 3R, 4, 12 and 13
- **Complies with**
 - NEMA Type 3R, 4, 12 and 13
 - IEC 529, IP65

Construction

- Formed 14 or 16 gauge steel.
- Smooth, continuously welded seams ground smooth.
- Door stiffeners are provided where required for increased strength and rigidity - designed to also permit additional mounting options.
- Formed lip on enclosure to exclude flowing liquids and contaminants.
- Door latches feature the added safety of quarter turn slot requiring use of tool for opening.
- Doors may be easily removed for modifications and are interchangeable.
- Oil resistant gaskets are permanently secured.
- Collar studs provided for mounting inner panel.
- Includes hardware kit with panel mounting nuts and sealing washers for wall mounting holes.
- Bonding stud provided on door and grounding stud installed in enclosure.
- Hinges are constructed from 304 stainless steel.
- Hinge pins are stainless steel.
- Quarter turn latches formed from mild steel diecast key lockable handle with black epoxy finish on 3 point latch.

Finish

- Cover and enclosure are finished in recoatable smooth ANSI/ASA 61 gray powder coating.

Accessories

- Air conditioners...see page **348-357**
- Blowers...see page **359**
- Breather kits...see page **374**
- DIN rails...see page **35**
- DIN rail mounting kit...see page **35**
- Door stop kit...see page **393**
- Filter fans...see page **360-367**
- Heaters...see page **369-371**
- Handles...see page **36**
- Inner panel...see page **34**
- Quarter turn inserts and keys ...see page **36**
- Literature pocket...see page **397**
- Mounting foot kit...see page **36**
- Swing panel...see page **35**
- Swing frame...see page **34**
- Replacement hinge pins...see page **34**
- Replacement quarter turn assemblies...see page **36**
- Thermostats...see page **374**
- Touch up paint...see page **396**
- UL/CSA approved hardware kit ...see page **382**
- Padlock Adapter (EPA)...see page **382**

Eclipse Series - NEMA 4, 12

Single Door Enclosures

Industrial Enclosures
Wallmount Enclosures

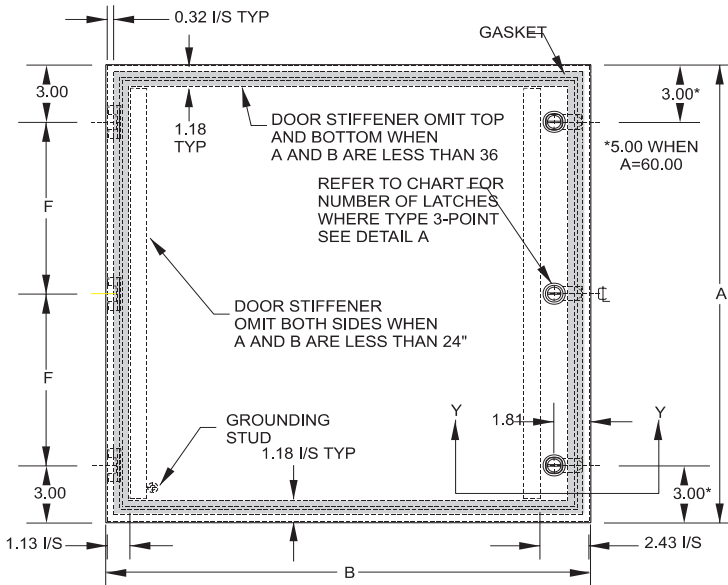

Front View

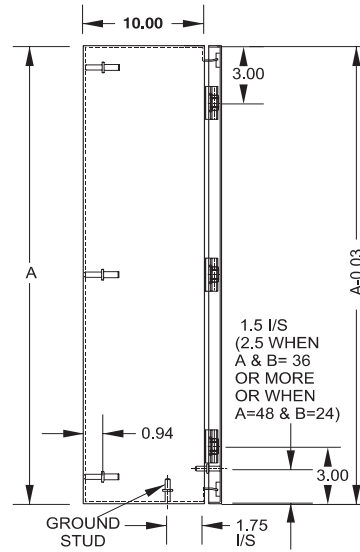

Side View

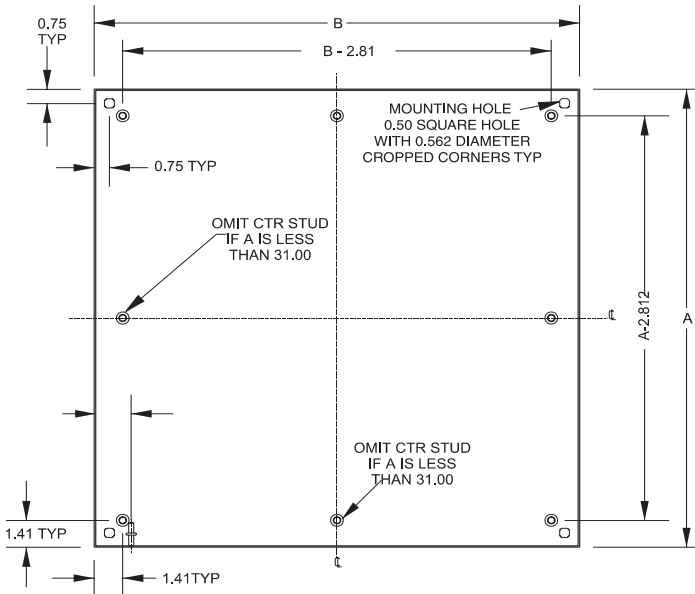

Front Section

(Door and Body Flange removed)

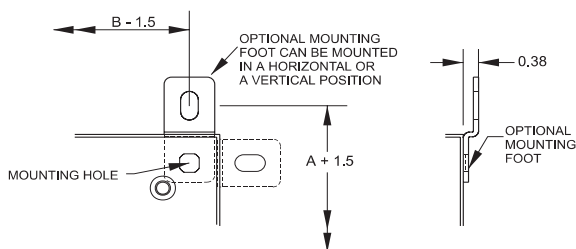

Mounting Detail

Door & Body Flange Removed

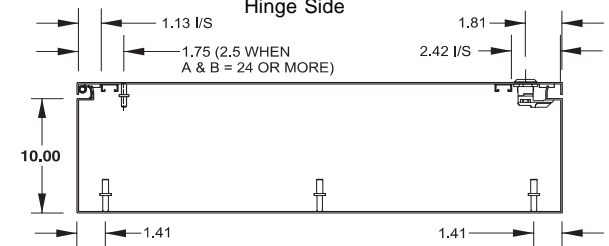

Hinge Side

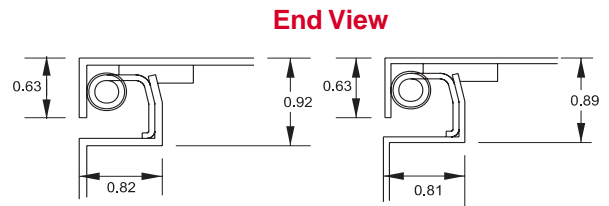

End View

Cross Section of 14 Gauge Body & Door

Cross Section of 16 Gauge Body & Door

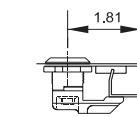

Quarter Turn Lock Section Y-Y

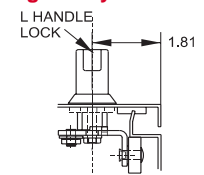

L Handle Lock Section X-X

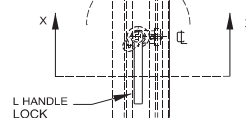

Detail A

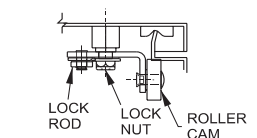

Cross Section Through End View

Door Cam Typ 2 pls when L handle is used

Refer to part number and dimension chart on previous page

Technical references and DXF downloads available at www.hammg.com

All dimensions in inches unless specified otherwise

Eclipse Series - NEMA 4, 12

Single Door Enclosures

Part No.	Overall Dimensions			Door/Body Gauge	Latches		Opt. Panel Part No.	Panel Size		# Hinges	Ship Wt.	
	A	B	C		Qty	Type		D	E		F	Ibs.
EN4SD12126GY	12	12	6	16	1	Qtr Turn	EP1212	10.2	10.2	2	6	12
EN4SD16126GY	16	12	6	16	1	Qtr Turn	EP1612	14.2	10.2	2	10	16
EN4SD16166GY	16	16	6	16	1	Qtr Turn	EP1616	14.2	14.2	2	10	19
EN4SD16206GY	16	20	6	16	1	Qtr Turn	EP1620	14.2	18.2	2	10	22
EN4SD20166GY	20	16	6	16	1	Qtr Turn	EP2016	18.2	14.2	2	14	22
EN4SD20206GY	20	20	6	16	1	Qtr Turn	EP2020	18.2	18.2	2	14	26
EN4SD24166GY	24	16	6	16	1	Qtr Turn	EP2416	22.2	14.2	2	18	26
EN4SD24206GY	24	20	6	16	1	Qtr Turn	EP2420	22.2	18.2	2	18	30
EN4SD24246GY	24	24	6	14	2	Qtr Turn	EP2424	22.2	22.2	2	18	37
EN4SD16128GY	16	12	8	16	1	Qtr Turn	EP1612	14.2	10.2	2	10	16
EN4SD16168GY	16	16	8	16	1	Qtr Turn	EP1616	14.2	14.2	2	10	21
EN4SD16208GY	16	20	8	16	1	Qtr Turn	EP1620	14.2	18.2	2	10	25
EN4SD20168GY	20	16	8	16	1	Qtr Turn	EP2016	18.2	14.2	2	14	25
EN4SD20208GY	20	20	8	16	1	Qtr Turn	EP2020	18.2	18.2	2	14	28
EN4SD20248GY	20	24	8	16	1	Qtr Turn	EP2024	18.2	22.2	2	14	32
EN4SD24168GY	24	16	8	16	1	Qtr Turn	EP2416	22.2	14.2	2	18	26
EN4SD24208GY	24	20	8	16	1	Qtr Turn	EP2420	22.2	18.2	2	18	32
EN4SD24248GY	24	24	8	14	2	Qtr Turn	EP2424	22.2	22.2	2	18	40
EN4SD24308GY	24	30	8	14	2	Qtr Turn	EP2430	22.2	28.2	2	18	48
EN4SD30208GY	30	20	8	14	2	Qtr Turn	EP3020	28.2	18.2	3	12	42
EN4SD30248GY	30	24	8	14	2	Qtr Turn	EP3024	28.2	22.2	3	12	46
EN4SD30308GY	30	30	8	14	2	Qtr Turn	EP3030	28.2	28.2	3	12	67
EN4SD36248GY	36	24	8	14	2	Qtr Turn	EP3624	34.2	22.2	3	15	55
EN4SD36308GY	36	30	8	14	2	Qtr Turn	EP3630	34.2	28.2	3	15	77
EN4SD36368GY	36	36	8	14	2	Qtr Turn	EP3636	34.2	34.2	3	15	94
EN4SD161210GY	16	12	10	16	1	Qtr. Turn	EP1612	14.2	10.2	2	10	18
EN4SD161610GY	16	16	10	16	1	Qtr. Turn	EP1616	14.2	14.2	2	10	23
EN4SD162010GY	16	20	10	16	1	Qtr. Turn	EP1620	14.2	18.2	2	10	28
EN4SD201610GY	20	16	10	16	1	Qtr. Turn	EP2016	18.2	14.2	2	14	28
EN4SD202010GY	20	20	10	16	1	Qtr. Turn	EP2020	18.2	18.2	2	14	31
EN4SD202410GY	20	24	10	16	1	Qtr. Turn	EP2024	18.2	22.2	2	14	36
EN4SD241610GY	24	16	10	16	1	Qtr. Turn	EP2416	22.2	14.2	2	18	30
EN4SD242010GY	24	20	10	16	1	Qtr. Turn	EP2420	22.2	18.2	2	18	36
EN4SD242410GY	24	24	10	14	2	Qtr. Turn	EP2424	22.2	22.2	2	18	45
EN4SD243010GY	24	30	10	14	2	Qtr. Turn	EP2430	22.2	28.2	2	18	53
EN4SD302010GY	30	20	10	14	2	Qtr. Turn	EP3020	28.2	18.2	3	12	47
EN4SD302410GY	30	24	10	14	2	Qtr. Turn	EP3024	28.2	22.2	3	12	53
EN4SD303010GY	30	30	10	14	2	Qtr. Turn	EP3030	28.2	28.2	3	12	75
EN4SD362410GY	36	24	10	14	2	Qtr. Turn	EP3624	34.2	22.2	3	15	70
EN4SD363010GY	36	30	10	14	2	Qtr. Turn	EP3630	34.2	28.2	3	15	84
EN4SD363610GY	36	36	10	14	2	Qtr. Turn	EP3636	34.2	34.2	3	15	100
EN4SD423610GY	42	36	10	14	1	3-point	EP4236	40.2	34.2	4	12	117
EN4SD482410GY	48	24	10	14	1	3-point	EP4824	46.2	22.2	4	14	95
EN4SD483610GY	48	36	10	14	1	3-point	EP4836	46.2	34.2	4	14	125
EN4SD603610GY	60	36	12	14	1	3-point	EP6036	58.2	34.2	4	18	150
EN4SD202012GY	20	20	12	16	1	Qtr Turn	EP2020	18.2	18.2	2	14	34
EN4SD242012GY	24	20	12	16	1	Qtr Turn	EP2420	22.2	18.2	2	18	38
EN4SD242412GY	24	24	12	14	2	Qtr Turn	EP2424	22.2	22.2	2	18	47
EN4SD302412GY	30	24	12	14	2	Qtr Turn	EP3024	28.2	22.2	3	12	57
EN4SD303012GY	30	30	12	14	2	Qtr Turn	EP3030	28.2	28.2	3	12	80
EN4SD362412GY	36	24	12	14	2	Qtr Turn	EP3624	34.2	22.2	3	15	62
EN4SD363012GY	36	30	12	14	2	Qtr Turn	EP3630	34.2	28.2	3	15	91

Technical references and DXF downloads available at www.hammg.com

All dimensions in inches unless specified otherwise

Eclipse Series - NEMA 4, 12

Single Door Enclosures

Continued from previous page.

Part No.	Overall Dimensions			Door/Body Gauge	Latches		Opt. Panel Part No.	Panel Size		# Hinges	Ship Wt.	
	A	B	C		Qty	Type		D	E		F	Ibs.
EN4SD363612GY	36	36	12	14	2	Qtr Turn	EP3636	34.2	34.2	3	15	104
EN4SD423612GY	42	36	12	14	1	3-point	EP4236	40.2	34.2	4	12	121
EN4SD482412GY	48	24	12	14	1	3-point	EP4824	46.2	22.2	4	14	98
EN4SD483612GY	48	36	12	14	1	3-point	EP4836	46.2	34.2	4	14	148
EN4SD603612GY	60	36	12	14	1	3-point	EP6036	58.2	34.2	4	18	165
EN4SD242416GY	24	24	16	14	2	Qtr Turn	EP2424	22.2	22.2	2	18	66
EN4SD363016GY	36	30	16	14	2	Qtr Turn	EP3630	34.2	28.2	3	15	102
EN4SD483616GY	48	36	16	14	1	3-point	EP4836	46.2	34.2	4	14	148
EN4SD242420GY	24	24	20	14	2	Qtr Turn	EP2424	22.2	22.2	2	18	70
EN4SD302420GY	30	24	20	14	2	Qtr Turn	EP3024	28.2	22.2	3	12	82
EN4SD363020GY	36	30	20	14	2	Qtr Turn	EP3630	34.2	28.2	3	15	117

Refer to drawing on following page

Optional Accessories

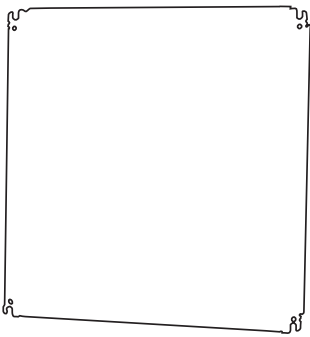

Inner panel...see page **34**

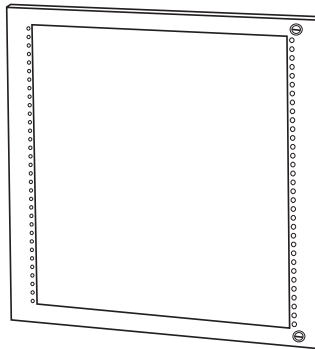

Swing frame...see page **34**

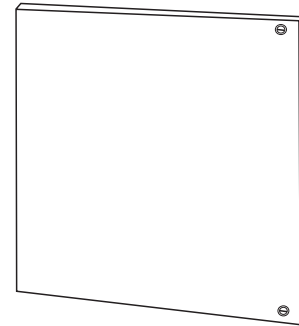

Swing panel...see page **35**

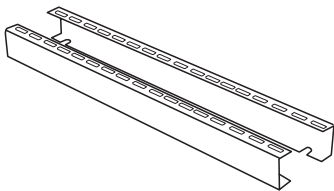

DIN rail mounting kit...see page **35**

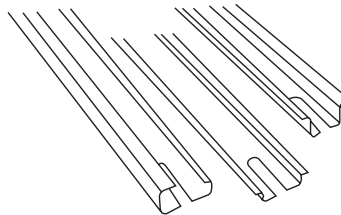

DIN rails...see page **35**



Handles...see page **36**

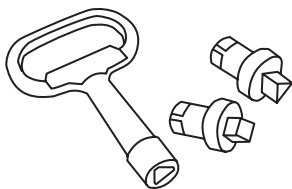

Quarter turn inserts and keys...see page **36**

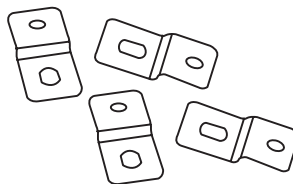

Mounting foot kit...see page **36**

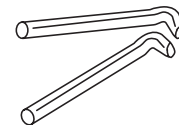

Replacement hinge pins...see page **34**

Technical references and DXF downloads available at www.hammg.com

All dimensions in inches unless specified otherwise

Quality Enclosures. Service Excellence.

Eclipse Series - NEMA 4, 12

Single Window Door Enclosures with Gland Plate



Order
Panel
Separately

Now with
Gland Plate



Application

- Designed to enclose electrical and/or electronic equipment in wallmount applications where viewing of component operation is necessary while maintaining protection ratings.
- Impressive styling features like hidden hinges, attractive latching systems make the Eclipse a suitable addition to any high-tech equipment installation.
- A wide range of sizes and practical accessories make this product line a complete package.
- For high temperature applications, a gasket retainer may be required, please refer to factory.

Standards

- UL 508 Type 12, 4
- CSA Type 12, 4
- **Complies with**
 - NEMA Type 12 and 4
 - IEC 529, IP65

Construction

- Formed 14 or 16 gauge steel.
- Full view UV resistant polycarbonate window allow maximum viewing area of inner panel.
- Smooth, continuously welded seams ground smooth.
- Door stiffeners are provided where required for increased strength and rigidity - designed to also permit additional mounting options.
- Formed lip on enclosure to exclude flowing liquids and contaminants.
- Door latches feature the added safety of quarter turn slot requiring use of tool for opening.
- Doors may be easily removed for modifications and are interchangeable.
- Oil resistant gaskets are permanently secured.
- Collar studs provided for mounting inner panel.
- Includes hardware kit with panel mounting nuts and sealing washers for wall mounting holes.
- Bonding stud provided on door and grounding stud installed in enclosure.
- Quarter turn latches formed from mild steel.
- Formed steel hinge with stainless steel hinge pins.
- Removable steel gland plate covers cutout in bottom allowing for easy cable entry preparation.

Finish

- Cover and enclosure are finished in recoatable textured RAL 7032 beige (CG1) powder coating.

Accessories

- Air conditioners...see page **348-357**
- Blowers...see page **359**
- Breather kits...see page **374**
- DIN rails...see page **35**
- DIN rail mounting kit...see page **35**
- Door stop kit...see page **393**
- Filter fans...see page **360-367**
- Heaters...see page **369-371**
- Handles...see page **36**
- Inner panel...see page **34**
- Quarter turn inserts and keys...see page **36**
- Literature pocket...see page **397**
- Mounting foot kit...see page **36**
- Swing frame...see page **35**
- Swing panel...see page **34**
- Replacement hinge pins...see page **34**
- Replacement quarter turn assemblies...see page **36**
- Thermostats...see page **374**
- Touch up paint...see page **396**
- UL/CSA approved hardware kit...see page **382**
- Padlock Adapter (EPA)...see page **382**

Eclipse Series - NEMA 4, 12

Single Window Door Enclosures with Gland Plate

Industrial Enclosures
Wallmount Enclosures

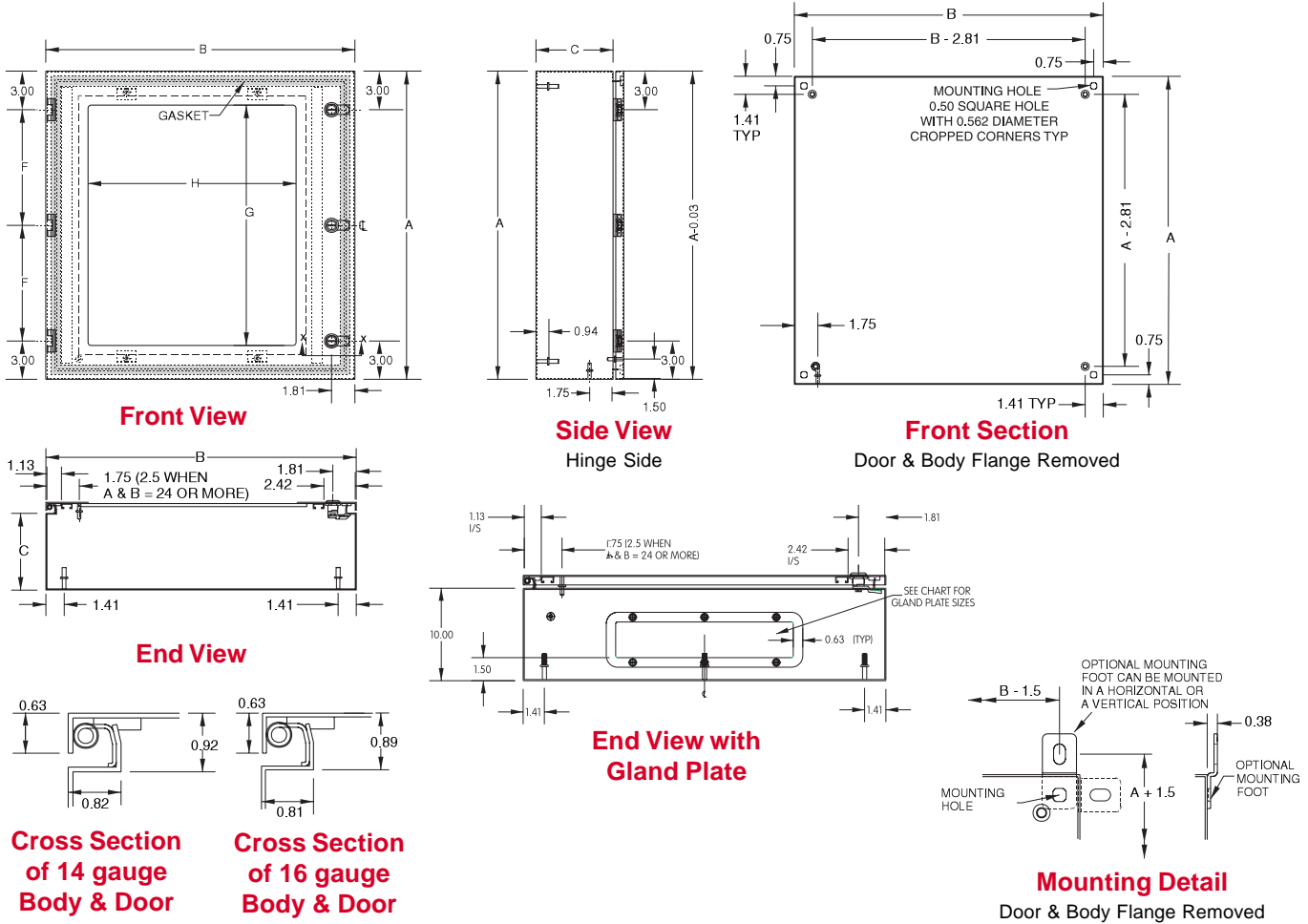

Part No.	Overall Dimensions			Door/ Body Gauge	Latch ¹ Qty	Hinge Qty	F	G	Viewing Area H	Optional Panel Part No.	Inner Panel Dimensions		Gland Plate Opening	Ship Wt. Lbs.
	A	B	C								D	E		
EN4SD16126WCG	16	12	6	16	1	2	10	11.33	6.90	EP1612	14.2	10.2	5.06 x 1.5	16
EN4SD20166WCG	20	16	6	16	1	2	14	15.33	10.90	EP2016	18.2	14.2	11.75 x 2.31	22
EN4SD20206WCG	20	20	6	16	1	2	14	15.33	14.90	EP2020	18.2	18.2	11.75 x 2.31	26
EN4SD24206WCG	24	20	6	16	1	2	18	19.33	14.90	EP2420	22.2	18.2	11.75 x 2.31	30
EN4SD24246WCG	24	24	6	14	2	2	18	18.71	16.15	EP2424	22.2	22.2	11.75 x 2.31	37
EN4SD16128WCG	16	12	8	16	1	2	10	11.33	6.90	EP1612	14.2	10.2	5.06 x 1.5	16
EN4SD20168WCG	20	16	8	16	1	2	14	15.33	10.90	EP2016	18.2	14.2	12.13 x 4.63	25
EN4SD20208WCG	20	20	8	16	1	2	14	15.33	14.90	EP2020	18.2	18.2	12.13 x 4.63	28
EN4SD24208WCG	24	20	8	16	1	2	18	19.33	14.90	EP2420	22.2	18.2	12.13 x 4.63	32
EN4SD24248WCG	24	24	8	14	2	2	18	18.71	16.15	EP2424	22.2	22.2	19.63 x 4.63	40
EN4SD30248WCG	30	24	8	14	2	3	12	24.71	16.15	EP3024	28.2	22.2	19.63 x 4.63	46
EN4SD202012WCG	20	20	12	16	1	2	18	15.33	14.90	EP2020	18.2	18.2	12.13 x 4.63	34
EN4SD242012WCG	24	20	12	16	1	2	18	19.33	14.90	EP2420	22.2	18.2	12.13 x 4.63	38
EN4SD242412WCG	24	24	12	14	2	2	18	18.71	16.15	EP2424	22.2	22.2	19.63 x 4.63	47
EN4SD302412WCG	30	24	12	14	2	3	12	24.71	16.15	EP3024	28.2	22.2	19.63 x 4.63	57
EN4SD242416WCG	24	24	16	14	2	2	18	18.71	16.15	EP2424	22.2	22.2	19.63 x 4.63	66
EN4SD242420WCG	24	24	20	14	2	2	18	18.71	16.15	EP2424	22.2	22.2	19.63 x 4.63	70
EN4SD302420WCG	30	24	20	14	2	3	12	24.71	16.15	EP3024	28.2	22.2	19.63 x 4.63	82

¹ All Window Door latch types are quarter turns.

Eclipse Series - NEMA 4, 12

Single Window Door Enclosures



**Order
Panel
Separately**



Application

- Designed to enclose electrical and/or electronic equipment in wallmount applications where viewing of component operation is necessary while maintaining protection ratings.
- Impressive styling features like hidden hinges, attractive latching systems make the Eclipse a suitable addition to any high-tech equipment installation.
- A wide range of sizes and practical accessories make this product line a complete package.
- For high temperature applications, a gasket retainer may be required, please refer to factory.

Standards

- UL 508 Type 3R, 4 and 12
- CSA Type 3R, 4 and 12
- **Complies with**
 - NEMA 3R, 4 and 12
 - IEC 529, IP66

Construction

- Formed 14 or 16 gauge steel.
- Full view UV resistant polycarbonate window allow maximum viewing area of inner panel.
- Smooth, continuously welded seams ground smooth.
- Door stiffeners are provided where required for increased strength and rigidity - designed to also permit additional mounting options.
- Formed lip on enclosure to exclude flowing liquids and contaminants.
- Door latches feature the added safety of quarter turn slot requiring use of tool for opening.
- Doors may be easily removed for modifications and are interchangeable.
- Oil resistant gaskets are permanently secured.
- Collar studs provided for mounting inner panel.
- Includes hardware kit with panel mounting nuts and sealing washers for wall mounting holes.
- Bonding stud provided on door and grounding stud installed in enclosure.
- Hinges are constructed from 304 stainless steel.
- Hinge pins are stainless steel.
- Quarter turn latches formed from mild steel diecast key lockable handle with black epoxy finish on 3 point latch.

Finish

- Cover and enclosure are finished in recoatable smooth ANSI/ASA 61 gray powder coating.

Accessories

- Air conditioners...see page **348-357**
- Blowers...see page **359**
- Breather kits...see page **374**
- DIN rails...see page **35**
- DIN rail mounting kit...see page **35**
- Door stop kit...see page **393**
- Filter fans...see page **360-367**
- Heaters...see page **369-371**
- Handles...see page **36**
- Inner panel...see page **34**
- Quarter turn inserts and keys...see page **36**
- Literature pocket...see page **397**
- Mounting foot kit...see page **36**
- Swing frame...see page **35**
- Swing panel...see page **34**
- Replacement hinge pins...see page **34**
- Replacement quarter turn assemblies...see page **36**
- Thermostats...see page **374**
- Touch up paint...see page **396**
- UL/CSA approved hardware kit...see page **382**
- Padlock Adapter (EPA)...see page **382**

Eclipse Series - NEMA 4, 12

Single Window Door Enclosures

Industrial Enclosures
Wallmount Enclosures

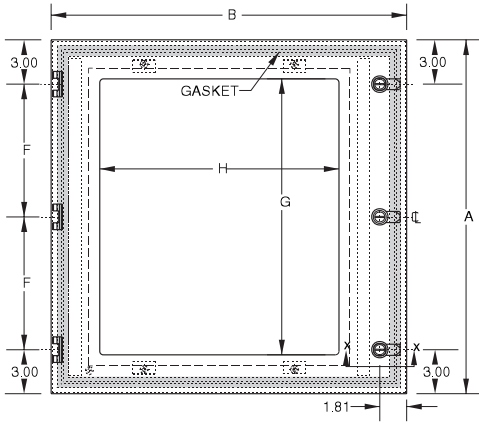

Front View

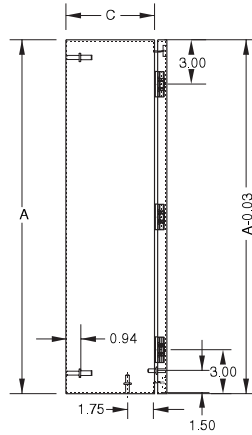

Side View
Hinge Side

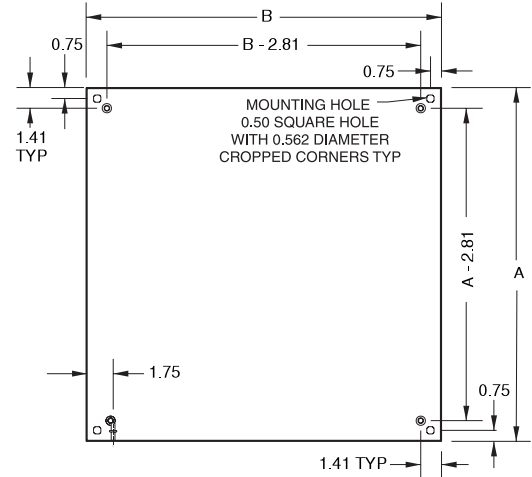

Front Section
Door & Body Flange Removed

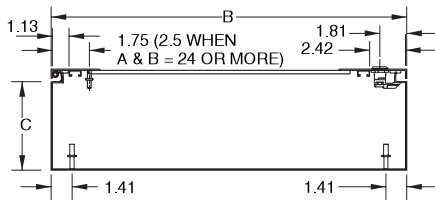

End View

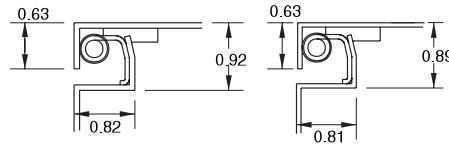

Cross Section of 14 gauge Body & Door **Cross Section of 16 gauge Body & Door**

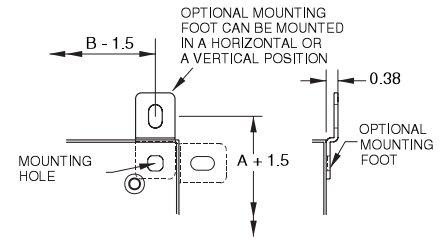

Mounting Detail
Door & Body Flange Removed

Part No.	Overall Dimensions			Door/Body Gauge	Latch ¹ Qty	Hinge Qty	F	Viewing Area		Optional Panel Part No.	Inner Panel Dimensions		Ship Wt. lbs.
	A	B	C					G	H		D	E	
EN4SD16126WGY	16	12	6	16	1	2	10	11.33	6.90	EP1612	14.2	10.2	16
EN4SD20166WGY	20	16	6	16	1	2	14	15.33	10.90	EP2016	18.2	14.2	22
EN4SD20206WGY	20	20	6	16	1	2	14	15.33	14.90	EP2020	18.2	18.2	26
EN4SD24206WGY	24	20	6	16	1	2	18	19.33	14.90	EP2420	22.2	18.2	30
EN4SD24246WGY	24	24	6	14	2	2	18	18.71	16.15	EP2424	22.2	22.2	37
EN4SD16128WGY	16	12	8	16	1	2	10	11.33	6.90	EP1612	14.2	10.2	16
EN4SD20168WGY	20	16	8	16	1	2	14	15.33	10.90	EP2016	18.2	14.2	25
EN4SD20208WGY	20	20	8	16	1	2	14	15.33	14.90	EP2020	18.2	18.2	28
EN4SD24208WGY	24	20	8	16	1	2	18	19.33	14.90	EP2420	22.2	18.2	32
EN4SD24248WGY	24	24	8	14	2	2	18	18.71	16.15	EP2424	22.2	22.2	40
EN4SD30248WGY	30	24	8	14	2	3	12	24.71	16.15	EP3024	28.2	22.2	46
EN4SD202012WGY	20	20	12	16	1	2	18	15.33	14.90	EP2020	18.2	18.2	34
EN4SD242012WGY	24	20	12	16	1	2	18	19.33	14.90	EP2420	22.2	18.2	38
EN4SD242412WGY	24	24	12	14	2	2	18	18.71	16.15	EP2424	22.2	22.2	47
EN4SD302412WGY	30	24	12	14	2	3	12	24.71	16.15	EP3024	28.2	22.2	57
EN4SD242416WGY	24	24	16	14	2	2	18	18.71	16.15	EP2424	22.2	22.2	66
EN4SD242420WGY	24	24	20	14	2	2	18	18.71	16.15	EP2424	22.2	22.2	70
EN4SD302420WGY	30	24	20	14	2	3	12	24.71	16.15	EP3024	28.2	22.2	82

¹ All Window Door latch types are quarter turns.

Eclipse Series- NEMA 4, 12

Two Door Enclosures with Gland Plate



Order
Panel
Separately

Now with
Gland Plate



Industrial Enclosures
Wallmount Enclosures

Application

- Designed to enclose electrical and/or electronic equipment and protect against harsh, industrial environments for wallmount applications.
- Impressive styling features like hidden hinges, attractive latching systems make the Eclipse a suitable addition to any high-tech equipment installation.
- A wide range of sizes and practical accessories make this product line a complete package.
- For high temperature applications, a gasket retainer may be required, please refer to factory.

Standards

- UL 508 Type 12, 4
- CSA Type 12, 4
- **Complies with**
 - NEMA Type 12 and 4
 - IEC 529, IP65

Construction

- Formed 14 gauge steel.
- Smooth, continuously welded seams ground smooth.
- Door stiffeners are provided for increased strength and rigidity - designed to also permit additional mounting options.
- Formed lip on enclosure to exclude flowing liquids and contaminants.
- Doors may be easily removed for modifications and are interchangeable.
- Oil resistant gaskets are permanently secured.
- Collar studs provided for mounting inner panel.
- Includes hardware kit with panel mounting nuts and sealing washers for wall mounting holes.
- Bonding stud provided on door and grounding stud installed in enclosure.
- Doors are secured with a three point key lockable handle.
- Key lockable handle is zinc diecast with black epoxy finish.
- Formed steel hinge with stainless steel hinge pins.
- Two removable steel gland plate covers cutout in bottom allowing for easy cable entry preparation.

Finish

- Cover and enclosure are finished in recoatable textured RAL 7032 beige (CG1) powder coating.

Accessories

- Air conditioners...see page **348-357**
- Blowers...see page **359**
- Breather kits...see page **374**
- DIN rails...see page **35**
- DIN rail mounting kit...see page **35**
- Door stop kit...see page **393**
- Filter fans...see page **360-367**
- Heaters...see page **369-371**
- Handles...see page **36**
- Inner panel...see page **34**
- Literature pocket...see page **397**
- Mounting foot kit...see page **36**
- Replacement hinge pins...see page **34**
- Thermostats...see page **374**
- Touch up paint...see page **396**
- UL/CSA approved hardware kit...see page **382**

Eclipse Series - NEMA 4, 12

Two Door Enclosures with Gland Plates

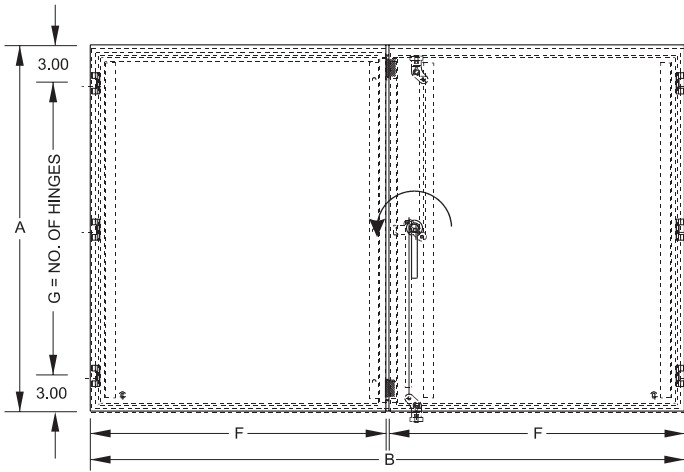

Front View

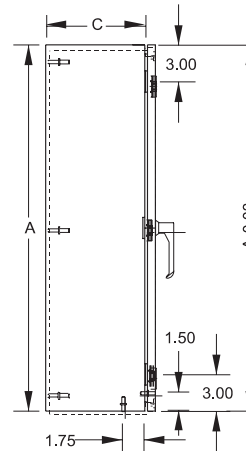

Side View - Hinge Side

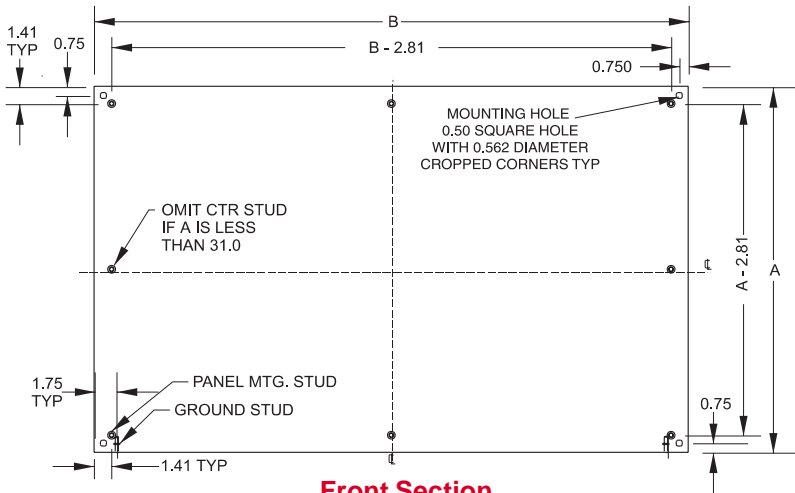

Front Section

Door & Body Flange Removed

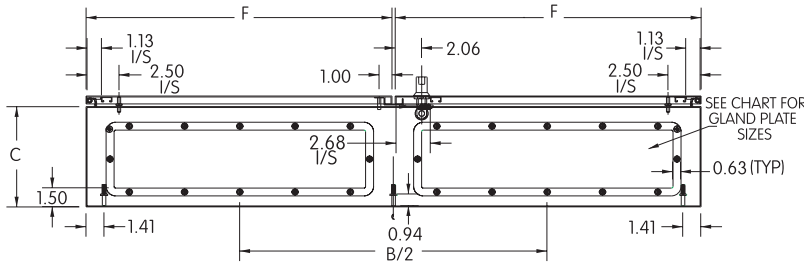

End View

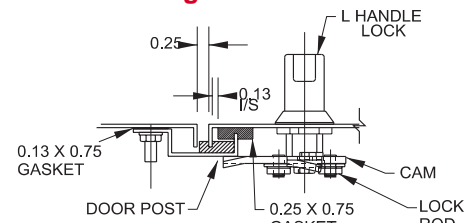

Cross Section of Handle Channel Detail

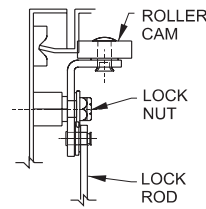

Cross Section End View of Top and Bottom
Door Cam typ 2 pls.

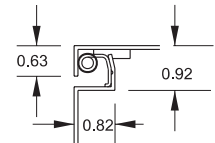

Cross Section of 14 gauge Body & Door

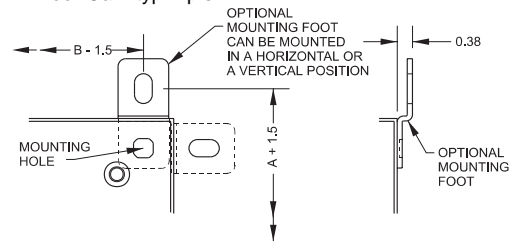

Mounting Detail

Door & Body Flange Removed

Part No.	Overall Dimensions			F	# Hinges	Opt. Panel Part No.	Panel Size		Gland Plate Openings	Ship Wt. Lbs.
	A	B	C				D	E		
EN4TD24428CG	24	42	8	20.88	2	EP2442	22.2	40.2	12.13 x 4.63	80
EN4TD30488CG	30	48	8	23.88	3	EP3048	28.2	46.2	19.63 x 4.63	105
EN4TD306012CG	30	60	12	29.88	3	EP3060	28.2	58.2	19.63 x 4.63	145
EN4TD364812CG	36	48	12	23.88	3	EP3648	34.2	46.2	19.63 x 4.63	135
EN4TD366012CG	36	60	12	29.88	3	EP3660	34.2	58.2	19.63 x 4.63	165

Eclipse Series- NEMA 4, 12

Two Door Enclosures



Order Panel Separately



Application

- Designed to enclose electrical and/or electronic equipment and protect against harsh, industrial environments for wallmount applications.
- Impressive styling features like hidden hinges, attractive latching systems make the Eclipse a suitable addition to any high-tech equipment installation.
- A wide range of sizes and practical accessories make this product line a complete package.
- For high temperature applications, a gasket retainer may be required, please refer to factory.

Standards

- UL 508 Type 3R, 4 and 12
- CSA Type 3R, 4 and 12
- **Complies with**
 - NEMA 3R, 4 and 12
 - IEC 529, IP66

Construction

- Formed 14 gauge steel.
- Smooth, continuously welded seams ground smooth.
- Door stiffeners are provided for increased strength and rigidity - also designed to permit additional mounting options.
- Formed lip on enclosure to exclude flowing liquids and contaminants.
- Doors may be easily removed for modifications and are interchangeable.
- Oil resistant gaskets are permanently secured.
- Collar studs provided for mounting inner panel.
- Includes hardware kit with panel mounting nuts and sealing washers for wall mounting holes.
- Bonding stud provided on door and grounding stud installed in enclosure.
- Doors are secured with a three point key lockable handle.
- Hinges are constructed from 304 stainless steel.
- Key lockable handle is zinc diecast with black epoxy finish.
- Hinge pins are stainless steel.

Finish

- Cover and enclosure are finished in recoatable smooth ANSI/ASA 61 gray powder coating.

Accessories

- Air conditioners...see page **348-357**
- Blowers...see page **359**
- Breather kits...see page **374**
- DIN rails...see page **35**
- DIN rail mounting kit...see page **35**
- Door stop kit...see page **393**
- Filter fans...see page **360-367**
- Heaters...see page **369-371**
- Handles...see page **36**
- Inner panel...see page **34**
- Literature pocket...see page **397**
- Mounting foot kit...see page **36**
- Replacement hinge pins...see page **34**
- Thermostats...see page **374**
- Touch up paint...see page **396**
- UL/CSA approved hardware kit...see page **382**

Eclipse Series - NEMA 4, 12

Two Door Enclosures

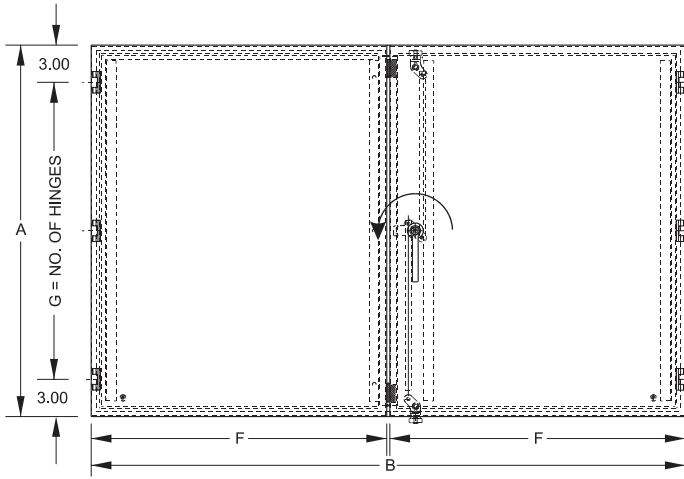

Front View

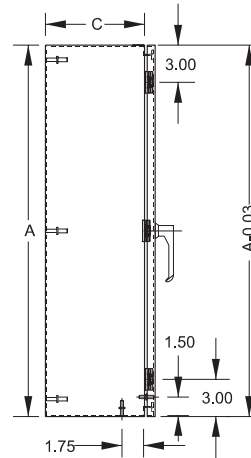

Side View - Hinge Side

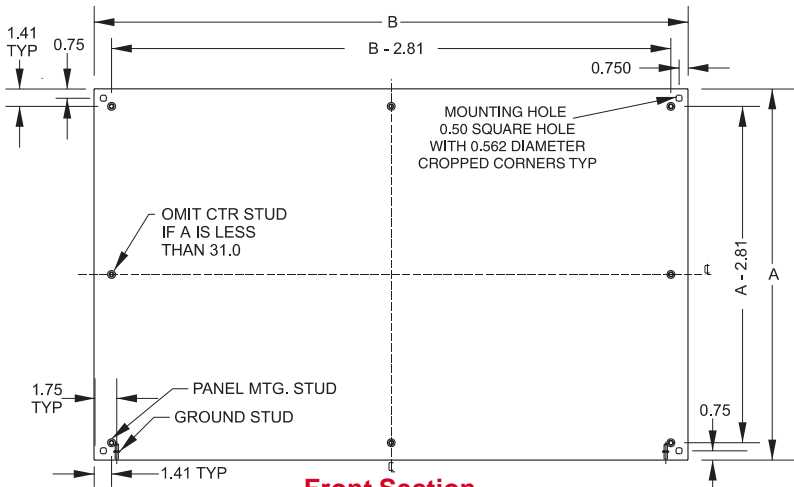

Front Section

Door & Body Flange Removed

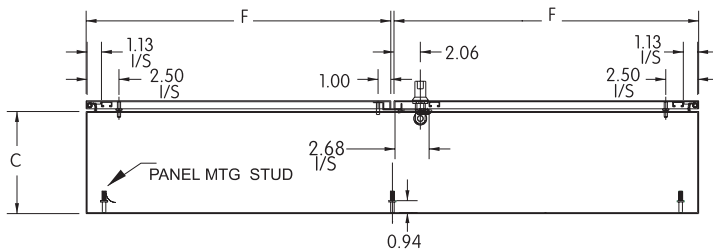

End View

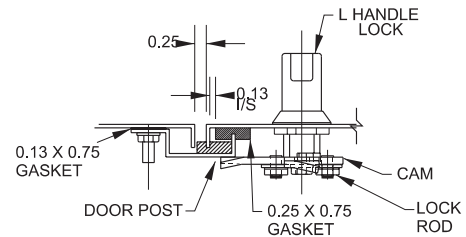

Cross Section of Handle Channel Detail

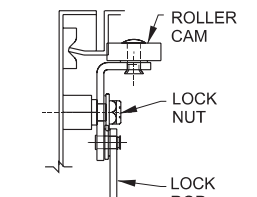

Cross Section End View of Top and Bottom
Door Cam typ 2 pls.

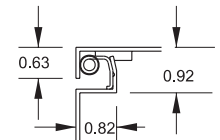

Cross Section of 14 gauge Body & Door

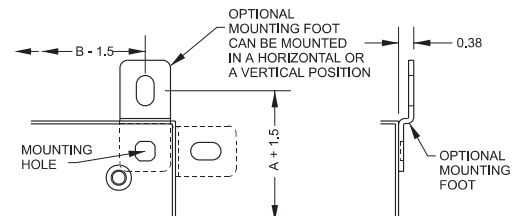

Mounting Detail

Door & Body Flange Removed

Part No.	Overall Dimensions			# Hinges	Opt. Panel Part No.	Panel Size		Ship Wt. lbs.	
	A	B	C			D	E		
EN4TD24428GY	24	42	8	20.88	2	EP2442	22.2	40.2	80
EN4TD30488GY	30	48	8	23.88	3	EP3048	28.2	46.2	105
EN4TD306012GY	30	60	12	29.88	3	EP3060	28.2	58.2	145
EN4TD364812GY	36	48	12	23.88	3	EP3648	34.2	46.2	135
EN4TD366012GY	36	60	12	29.88	3	EP3660	34.2	58.2	165

Eclipse Series - NEMA 4, 12

Accessories

Industrial Enclosures
Wallmount Enclosures

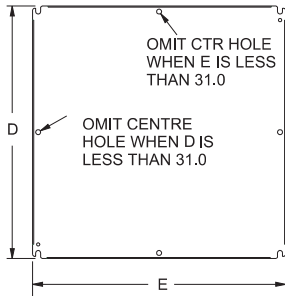

Eclipse Inner Panel

- Larger than standard NEMA panel used in same sized enclosure.
- 12 or 14 gauge steel construction (see chart below).
- Larger sizes have 2 or 4 formed flanges for added strength.
- Slotted corner design for easier mounting.
- Finished in white or unpainted galvanized.

Mild Steel Part No.	Galvanized Part No.	Size		
		D	E	Gauge
EP1212	EPG1212	10.2	10.2	14
EP1612	EPG1612	14.2	10.2	14
EP1616	EPG1616	14.2	14.2	12
EP1620	EPG1620	14.2	18.2	12
EP2016	EPG2016	18.2	14.2	12
EP2020	EPG2020	18.2	18.2	12
EP2024	EPG2024	18.2	22.2	12
EP2416	EPG2416	22.2	14.2	12
EP2420	EPG2420	22.2	18.2	12
EP2424	EPG2424	22.2	22.2	12
EP2430	EPG2430	22.2	28.2	12
EP2442	EPG2442	22.2	40.2	12
EP3020	EPG3020	28.2	18.2	12

Mild Steel Part No.	Galvanized Part No.	Size		
		D	E	Gauge
EP3024	EPG3024	28.2	22.2	12
EP3030	EPG3030	28.2	28.2	12
EP3048	EPG3048	28.2	46.2	12
EP3060	EPG3060	28.2	58.2	12
EP3624	EPG3624	34.2	22.2	12
EP3630	EPG3630	34.2	28.2	12
EP3636	EPG3636	34.2	34.2	12
EP3648	EPG3648	34.2	46.2	12
EP3660	EPG3660	34.2	58.2	12
EP4236	EPG4236	40.2	34.2	12
EP4824	EPG4824	46.2	22.2	12
EP4836	EPG4836	46.2	34.2	12
EP6036	EPG6036	58.2	34.2	12

For sizing, refer to master selection table...see page 38



Eclipse Swing Panel

- Hinged panel allows access to internally mounted equipment.
- 12 gauge steel construction.
- Slotted quarter turn latches provide closure.
- Adding optional locking quarter turn latches (Part Number **EQTRL**...see page 36) convert this to a dead front panel.
- Complete with 4-6" depth adjustment channels.
- Hardware kit maintains UL, CSA and NEMA ratings when field installed.
- Finished in white.



Part No.	Fits Enclosure Size (A x B)
ESP1212	12 x 12
ESP1612	16 x 12
ESP1616	16 x 16
ESP2016	20 x 16
ESP2416	24 x 16
ESP1620	16 x 20
ESP2020	20 x 20
ESP2420	24 x 20
ESP3020	30 x 20
ESP2024	20 x 24
ESP2424	24 x 24
ESP3024	30 x 24
ESP3624	36 x 24
ESP3030	30 x 30
ESP3630	36 x 30
ESP3636	36 x 36

For sizing, refer to master selection table...see page 38



Eclipse Replacement Hinge Pins

- These are supplied with enclosure but offered here as replacements should originals be misplaced.
- Packaged in quantities of 5.

Part No.	Material
EPINS	Zinc plated steel hinge pin
EPINSS	Stainless steel hinge pin

Eclipse Series - NEMA 4, 12

Accessories



Eclipse Swing Frame

- Provides 19" rack mounting with full EIA spacing (punched holes).
- Hinges allow easy equipment access.
- Slotted quarter turn latches provide closure.
- Adding optional locking quarter turn latches (**EQTRL**...see page 36) provides added security.
- Complete with 4-6" depth adjustment channels.
- Order package of 25 clip nuts separately (Part No. **1421N25**...see page 387).
- Hardware kit maintains UL, CSA and NEMA ratings when field installed.
- Finished in black.

Part No.	Fits Enclosure Size (A x B)		Rack Spacing	
	Width	Height (Units)	Width	Height (Units)
ESF2424	24 x 24	19	11	11
ESF3024	30 x 24	19	14	14
ESF3624	36 x 24	19	17	17

For sizing, refer to master selection table...see page 38

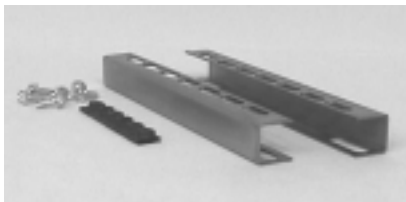

DIN Rail Mounting Kit

- Field installable.
- Mounts directly to panel collar studs (panel not required).
- Accepts optional DIN rails, see below.
- DIN rails available separately.
- Zinc plated, yellow dichromate.

Part No.	A	B	C
2DMK12	10	1.25	7
2DMK16	14	0.75	11
2DMK20	18	0.88	14
2DMK24	22	1.00	17
2DMK30	28	0.88	22

For sizing, refer to master selection table...see page 38

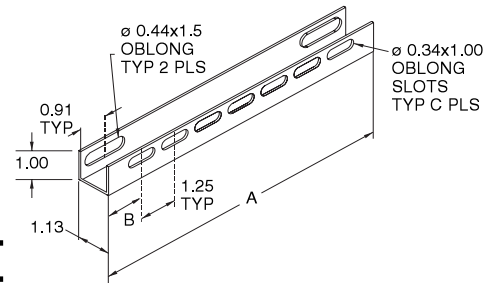

DIN Rails

- Field installable.
- Includes a set of 3 plated rails.
- Available in 3 industry standard profiles - DIN 1, DIN 3, and CENELEC.
- DIN rail mounting kit required for installation (see above).
- Rails have a 0.28 x 1.25 oblong slot on each end.
- Zinc plated, yellow dichromate.

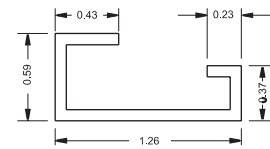

Asymmetric DIN 1 Profile

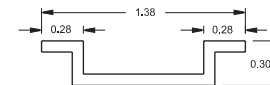

Symmetric DIN 3 Profile

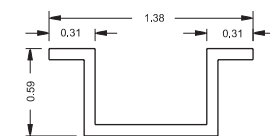

CENELEC Profile

Asymmetric Din 1 Profile Part No.	Symmetric Din 3 Profile Part No.	Cenelec Profile Part No.	Length
2D1K12	2D2K12	2DCK12	9.25
2D1K16	2D2K16	2DCK16	13.25
2D1K20	2D2K20	2DCK20	17.25
2D1K24	2D2K24	2DCK24	21.25
2D1K30	2D2K30	2DCK30	27.25

For sizing, refer to master selection table...see page 38

Eclipse Series- NEMA 4, 12

Accessories



Quarter Turn Inserts and Keys

- Field installable inserts replace standard quarter turn slot.
- Available in 7mm square and triangle formats, as well as slotted.
- Square and triangle inserts provide extra security since standard screw drivers cannot open.
- Keys sold separately from inserts.
- Maintains NEMA, UL and CSA 12, 4 and 4X ratings.

Part No.	Description
2SQI7	7mm square insert, black
2SQK7	7mm square key, fits 2SQI7
2TRI7	7mm triangle insert, black
2TRK7	7mm triangle key, fits 2TRI7
2SLI	Slotted insert, black



Replacement Quarter Turn Assemblies

- Field installable.
- Interchangeable with standard quarter turn latches.
- Maintains NEMA, UL and CSA ratings as noted.

Part No.	Description	Material	NEMA Rating
EQTRL¹	Locking Qtr Turn	Zinc Die/Chrome	n/a (internal use only)
2QTR	Slotted Qtr Turn	Zinc Die/Black	12, 4
2SSQTR	Slotted Qtr Turn	Stainless steel	12, 4, 4X
2WKL	Wing knob lock	Zinc Die/Black	12, 4
2QPL	Padlockable quarter turn latch	Zinc Die/Black	12, 4

¹ For use with Swing Frame/Panel. ...see page 35. All others for use with enclosures.



Handles

- Field installable.
- Interchangeable with standard quarter turn latches.
- Maintain NEMA, UL and CSA ratings as noted.

Part No.	Description	Material	NEMA Rating
EHTL	Locking T Handle	Zinc Die/Black	12, 4
EHLL	Locking L Handle	Zinc Die/Black	12, 4
EHLPL	Padlockable L Handle	Zinc Die/Black	12
EHLPLSS	Padlockable L Handle	Stainless Steel	12, 4, 4X
EHLNLSS	Non Locking L Handle	Stainless Steel	12, 4, 4X



Eclipse Mounting Foot Kit

- Maintains UL, CSA and NEMA ratings.
- Field installable.
- Pilot sits squarely into enclosure mounting holes for horizontal or vertical positioning.
- Available in plated black and stainless steel.
- Packaged in quantities of four.

Part No.	Material
EZPMF	Mild Steel
ESSMF	Type 304 Stainless
ES16MF	Type 316 Stainless

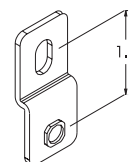

Eclipse Series - NEMA 4, 12

Eclipse Series- NEMA 4

Master Selection Table

Single Door Enclosures

Overall Dimensions			Solid Door	Solid Door	Window Door	Window Door	Inner Panel ¹	Swing Panel	Swing Frame
A	B	C	w/ Gland Plate		w/ Gland Plate				
12	12	6	EN4SD12126CG	EN4SD12126GY			EP1212	ESP1212	
16	12	6	EN4SD16126CG	EN4SD16126GY	EN4SD16126WCG	EN4SD16126WGY	EP1612	ESP1612	
16	16	6	EN4SD16166CG	EN4SD16166GY			EP1616	ESP1616	
16	20	6	EN4SD16206CG	EN4SD16206GY			EP1620	ESP1620	
20	16	6	EN4SD20166CG	EN4SD20166GY	EN4SD20166WCG	EN4SD20166WGY	EP2016	ESP2016	
20	20	6	EN4SD20206CG	EN4SD20206GY	EN4SD20206WCG	EN4SD20206WGY	EP2020	ESP2020	
24	16	6	EN4SD24166CG	EN4SD24166GY			EP2416	ESP2416	
24	20	6	EN4SD24206CG	EN4SD24206GY	EN4SD24206WCG	EN4SD24206WGY	EP2420	ESP2420	
24	24	6	EN4SD24246CG	EN4SD24246GY	EN4SD24246WCG	EN4SD24246WGY	EP2424	ESP2424	ESF2424
16	12	8	EN4SD16128CG	EN4SD16128GY	EN4SD16128WCG	EN4SD16128WGY	EP1612	ESP1612	
16	16	8	EN4SD16168CG	EN4SD16168GY			EP1616	ESP1616	
16	20	8	EN4SD16208CG	EN4SD16208GY			EP1620	ESP1620	
20	16	8	EN4SD20168CG	EN4SD20168GY	EN4SD20168WCG	EN4SD20168WGY	EP2016	ESP2016	
20	20	8	EN4SD20208CG	EN4SD20208GY	EN4SD20208WCG	EN4SD20208WGY	EP2020	ESP2020	
20	24	8	EN4SD20248CG	EN4SD20248GY			EP2024	ESP2024	
24	16	8	EN4SD24168CG	EN4SD24168GY			EP2416	ESP2416	
24	20	8	EN4SD24208CG	EN4SD24208GY	EN4SD24208WCG	EN4SD24208WGY	EP2420	ESP2420	
24	24	8	EN4SD24248CG	EN4SD24248GY	EN4SD24248WCG	EN4SD24248WGY	EP2424	ESP2424	ESF2424
24	30	8	EN4SD24308CG	EN4SD24308GY			EP2430		
30	20	8	EN4SD30208CG	EN4SD30208GY			EP3020	ESP3020	
30	24	8	EN4SD30248CG	EN4SD30248GY	EN4SD30248WCG	EN4SD30248WGY	EP3024	ESP3024	ESF3024
30	30	8	EN4SD30308CG	EN4SD30308GY			EP3030	ESP3030	
36	24	8	EN4SD36248CG	EN4SD36248GY			EP3624	ESP3624	ESF3624
36	30	8	EN4SD36308CG	EN4SD36308GY			EP3630	ESP3630	
36	36	8	EN4SD36368CG	EN4SD36368GY			EP3636	ESP3636	
16	12	10	EN4SD161210CG	EN4SD161210GY			EP1612	ESP1612	
16	16	10	EN4SD161610CG	EN4SD161610GY			EP1616	ESP1616	
16	20	10	EN4SD162010CG	EN4SD162010GY			EP1620	ESP1620	
20	16	10	EN4SD201610CG	EN4SD201610GY			EP2016	ESP2016	
20	20	10	EN4SD202010CG	EN4SD202010GY			EP2020	ESP2020	
20	24	10	EN4SD202410CG	EN4SD202410GY			EP2024	ESP2024	
24	16	10	EN4SD241610CG	EN4SD241610GY			EP2416	ESP2416	
24	20	10	EN4SD242010CG	EN4SD242010GY			EP2420	ESP2420	
24	24	10	EN4SD242410CG	EN4SD242410GY			EP2424	ESP2424	ESF2424
24	30	10	EN4SD243010CG	EN4SD243010GY			EP2430	ESP2430	
30	20	10	EN4SD302010CG	EN4SD302010GY			EP3020	ESP3020	
30	24	10	EN4SD302410CG	EN4SD302410GY			EP3024	ESP3024	ESF3024
30	30	10	EN4SD303010CG	EN4SD303010GY			EP3030	ESP3030	
36	24	10	EN4SD362410CG	EN4SD362410GY			EP3624	ESP3624	ESF3624
36	30	10	EN4SD363010CG	EN4SD363010GY			EP3630	ESP3630	
36	36	10	EN4SD363610CG	EN4SD363610GY			EP3636	ESP3636	
42	36	10	EN4SD423610CG	EN4SD423610GY			EP4236		
48	24	10	EN4SD482410CG	EN4SD482410GY			EP4824		
48	36	10	EN4SD483610CG	EN4SD483610GY			EP4836		
60	36	10	ESD603610CG*				EP6036		

*Does not meet Nema 4 requirements

¹Galvanized panels also available...see page 34.

Industrial Enclosures
Wallmount Enclosures

Eclipse Series - NEMA 4

Master Selection Table

Overall Dimensions			Solid Door	Solid Door	Window Door	Window Door	Inner	Swing	Swing
A	B	C	w/ Gland Plate		w/ Gland Plate		Panel	Panel	Frame
20	20	12	EN4SD202012CG	EN4SD202012GY	EN4SD202012WCG	EN4SD202012WGY	EP2020	ESP2020	
24	20	12	EN4SD242012CG	EN4SD242012GY	EN4SD242012WCG	EN4SD242012WGY	EP2420	ESP2420	
24	24	12	EN4SD242412CG	EN4SD242412GY	EN4SD242412WCG	EN4SD242412WGY	EP2424	ESP2424	ESF2424
30	24	12	EN4SD302412CG	EN4SD302412GY	EN4SD302412WCG	EN4SD302412WGY	EP3024	ESP3024	ESF3024
30	30	12	EN4SD303012CG	EN4SD303012GY			EP3030	ESP3030	
36	24	12	EN4SD362412CG	EN4SD362412GY			EP3624	ESP3624	ESF3624
36	30	12	EN4SD363012CG	EN4SD363012GY			EP3630	ESP3630	
36	36	12	EN4SD363612CG	EN4SD363612GY			EP3636	ESP3636	
42	36	12	EN4SD423612CG	EN4SD423612GY			EP4236		
48	24	12	EN4SD482412CG	EN4SD482412GY			EP4824		
48	36	12	EN4SD483612CG	EN4SD483612GY			EP4836		
60	36	12	ESD603612CG*				EP6036		
24	24	16	EN4SD242416CG	EN4SD242416GY	EN4SD242416WCG	EN4SD242416WGY	EP2424	ESP2424	ESF2424
36	30	16	EN4SD363016CG	EN4SD363016GY			EP3630	ESP3630	
48	36	16	EN4SD483616CG	EN4SD483616GY			EP4836		
24	24	20	EN4SD242420CG	EN4SD242420GY	EN4SD242420WCG	EN4SD242420WGY	EP2424	ESP2424	ESF2424
30	24	20	EN4N4SD302420CG	EN4SD302420GY	EN4SD302420WCG	EN4SD302420WGY	EP3024	ESP3024	ESF3024
36	30	20	EN4SD363020CG	EN4SD363020GY			EP3630	ESP3630	
Double Door Enclosures									
24	42	8	EN4TD24428CG	EN4TD24428GY			EP2442		
30	48	8	EN4TD30488CG	EN4TD30488GY			EP3048		
30	60	12	EN4TD306012CG	EN4TD306012GY			EP3060		
36	48	12	EN4TD364812CG	EN4TD364812GY			EP3648		
36	60	12	EN4TD366012CG	EN4TD366012GY			EP3660		

*Does not meet Nema 4 requirements

Series 2000- NEMA 4 Single Door Enclosures



**Order
Panel
Separately**



Application

- Designed to enclose electrical and/or electronic equipment and protect against harsh, industrial environments for wallmount applications.
- Provides protection where equipment may be hosed down or otherwise be very wet, or in outdoor applications for full weather protection.
- Attractive design offers high tech styling and convenient user features.
- For high temperature applications, a gasket retainer may be required, please refer to factory.

Standards

- UL 508 Type 3R, 4, and 12
- CSA Type 3R, 4 and 12
- **Complies with**
 - NEMA Type 3R, 4, 12 and 13
 - IEC 529, IP66

Construction

- Formed 14 gauge steel bodies with 14 gauge steel doors.
- Smooth, continuously welded seams without knockouts, cutouts or holes.
- Body stiffeners are provided where required for increased strength and rigidity.
- Door profiles provide increased strength and are pre-punched to provide mounting options.
- Formed lip on door and enclosure exclude flowing liquids and contaminants.
- Doors may be easily removed, reversed or interchanged.
- Slotted quarter turn oil-tight latches secure the door, with optional tamper resistant and locking latches available.
- Steel hinges are painted black.
- Oil resistant gaskets are permanently secured.
- Compression stops ensure optimum gasket performance.
- Collar studs are provided for mounting inner panels and accessories.
- A bonding screw is provided on the door and a grounding stud is provided in the enclosure.
- A literature pocket is provided for the inside of the door except as noted.¹

Finish

- Cover and enclosure are finished in recoatable smooth ANSI/ASA 61 gray powder coating.
- Optional steel inner panels are finished in white powder coating.

Accessories

- Air conditioners...see page **348-357**
- Blowers...see page **359**
- Breather kits...see page **374**
- Depth extension ring kit...see page **42**
- DIN rails...see page **44**
- DIN rail mounting kit...see page **44**
- Filter fans...see page **360-367**
- Fixed rack mounting kits...see page **44**
- Floor stand kits...see page **394**
- Heaters...see page **369-371**
- Inner panels...see page **42**
- Locking handles...see page **45**
- Louvered ventilating plates...see page **396**
- Mounting foot kits...see page **45**
- Quarter turn inserts & keys...see page **45**
- Replacement quarter turn assemblies...see page **45**
- Swing frames...see page **43**
- Swing panels...see page **43**
- Terminal kit assemblies...see page **386**
- Thermostats...see page **374**
- Window doors...see page **42**
- Padlock Adapter (EPA)...see page **382**

Series 2000 - NEMA 4 Single Door Enclosures

Industrial Enclosures
Wallmount Enclosures

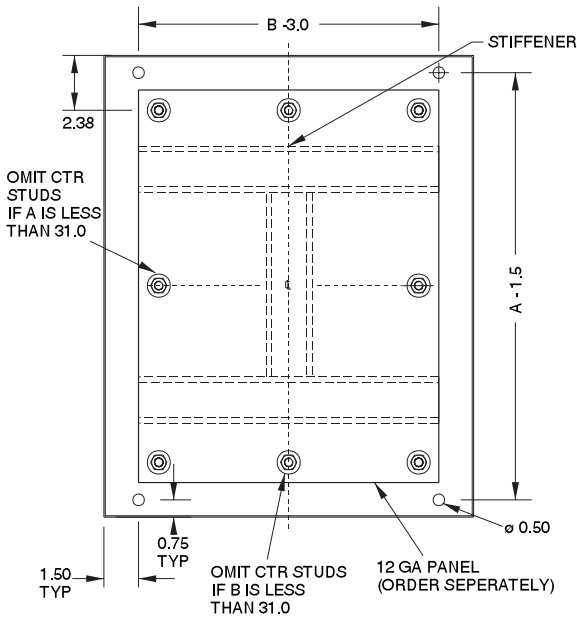

Section Y-Y

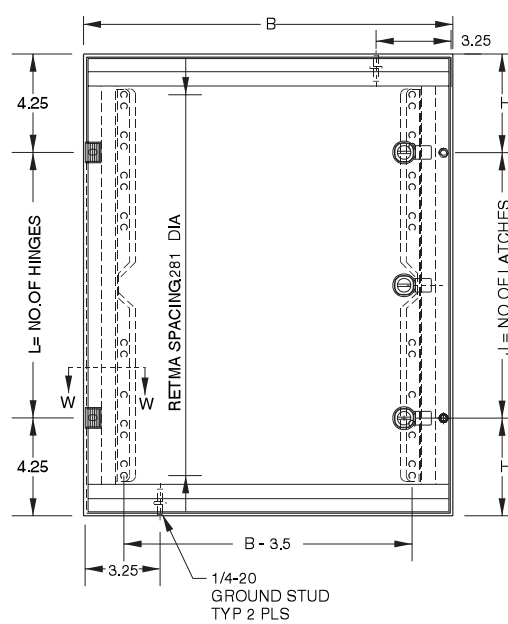

Front View

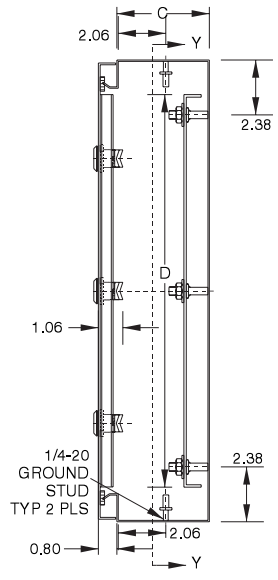

Side View

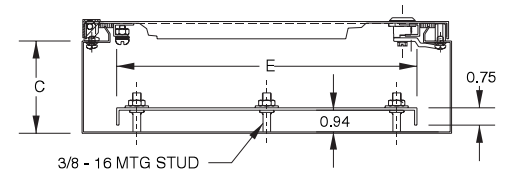

Top View

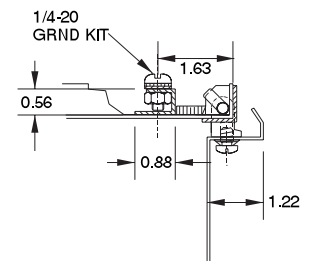

**Hinge Detail
(Section W-W)**

(Shown with door open 180°)

Enclosure Part No.	A	B	C	Opt. Panel Part No.	Panel Dim. D	E	H	J	L	Ship Wt. lbs
2P12126 ¹	12	12	6	18P0909	9	9	—	1	2	14
2P16126 ¹	16	12	6	18P1309	13	9	—	1	2	17
2P16166	16	16	6	18P1313	13	13	—	1	2	21
2P20166	20	16	6	18P1713	17	13	—	1	2	25
2P20206	20	20	6	18P1717	17	17	—	1	2	28
2P20168	20	16	8	18P1713	17	13	—	1	2	27
2P24168	24	16	8	18P2113	21	13	—	1	2	30
2P16208	16	20	8	18P1713	13	17	—	1	2	26
2P20208	20	20	8	18P1717	17	17	—	1	2	32
2P24208	24	20	8	18P2117	21	17	—	1	2	35
2P30208	30	20	8	18P2717	27	17	4.25	2	3	44
2P20248	20	24	8	18P2117	17	21	—	1	2	36
2P24248	24	24	8	18P2121	21	21	4.25	2	2	46
2P30248	30	24	8	18P2721	27	21	4.25	2	3	56
2P36248	36	24	8	18P3321	33	21	4.25	2	3	64
2P30308	30	30	8	18P2727	27	27	4.25	2	3	74
2P36308	36	30	8	18P3327	33	27	4.25	2	3	91
2P242412	24	24	12	18P2121	21	21	4.25	2	2	53
2P302412	30	24	12	18P2721	27	21	4.25	2	3	69
2P482412	48	24	12	18P4521	45	21	6.00	3	4	130
2P363012	36	30	12	18P3327	33	27	4.25	2	3	98
2P423612	42	36	12	18P3933	39	33	6.00	3	4	135
2P483612	48	36	12	18P4533	45	33	6.00	3	4	147
2P242416	24	24	16	18P2121	21	21	4.25	2	2	75
2P363016	36	30	16	18P3327	33	27	4.25	2	3	117
2P483616	48	36	16	18P4533	45	33	6.00	3	4	158

¹ Less literature pocket

Technical references and DXF downloads available at www.hamfmfg.com

All dimensions in inches unless specified otherwise

Quality Enclosures. Service Excellence.

Series 2000 - NEMA 4 Accessories

Series 2000 Inner Panel

- 12 gauge steel.
- Larger panels have two or four formed flanges.
- Some larger panels are 10 gauge.
- Hardware to mount inner panels is included with Series 2000 enclosures.
- Finished in white.

Part No.	Height	Width
18P0909	9	9
18P1309	13	9
18P1313	13	13
18P1713	17	13
18P1717	17	17
18P2113	21	13
18P2117	21	17
18P2121	21	21
18P2717	27	17

Part No.	Height	Width
18P2721	27	21
18P2727	27	27
18P3321	33	21
18P3327	33	27
18P3933	39	33
18P4521	45	21
18P4533	45	33

For sizing, refer to master selection table...see page 46.

Industrial Enclosures
Wallmount Enclosures

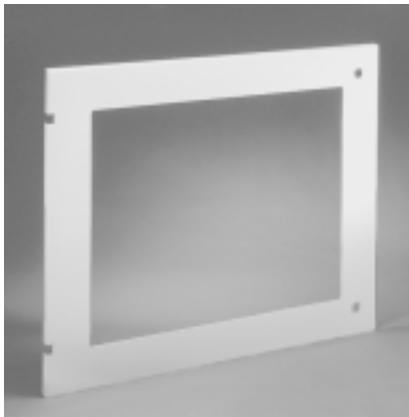

Window Door

- Lexan window doors are field installable
- Maintains NEMA rating.
- Use mounting hardware supplied with standard door to install window door.

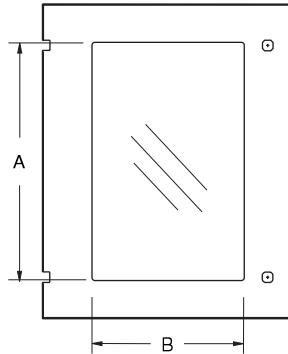

Type 4

Part No.	A	B
2PW1212	5.25	5.25
2PW1612	9.25	5.25
2PW1616	9.25	9.25
2PW1620	9.25	13.25
2PW2016	13.25	9.25
2PW2020	13.25	13.25
2PW2024	12.75	16.75
2PW2416	16.75	8.75
2PW2420	16.75	12.75
2PW2424	16.75	16.75
2PW3020	22.75	12.75
2PW3024	22.25	16.25
2PW3030	22.25	22.25
2PW3624	28.25	16.25
2PW3630	28.25	22.25
2PW4236	34.25	28.25
2PW4824	40.25	16.25
2PW4836	40.25	28.25

For sizing, refer to master selection table...see page 46.



Depth Extension Ring Kit

- Formed 14 gauge steel.
- Adds 8 inches to enclosure depth.
- Maintains NEMA rating (silicone seal is required to maintain rating - not supplied).
- Type 4 finished in gray.

Type 4

Part No.	A	B
2PX2024	20	24
2PX2424	24	24
2PX3024	30	24
2PX3624	36	24
2PX3630	36	30

For sizing, refer to master selection table...see page 46.

Series 2000 - NEMA 4 Accessories

Swing Panel

- Hinged panel allows access to internally mounted equipment.
- Slotted quarter turn latches provide closure.
- 12 gauge steel construction.
- Adding optional locking quarter turn latches (Part Number **EQTRL**...see page 45) convert this to a dead front panel.
- Complete with 4-6" depth adjustment channels.
- Hardware kit maintains UL, CSA and NEMA ratings when field installed.
- Finished in white.

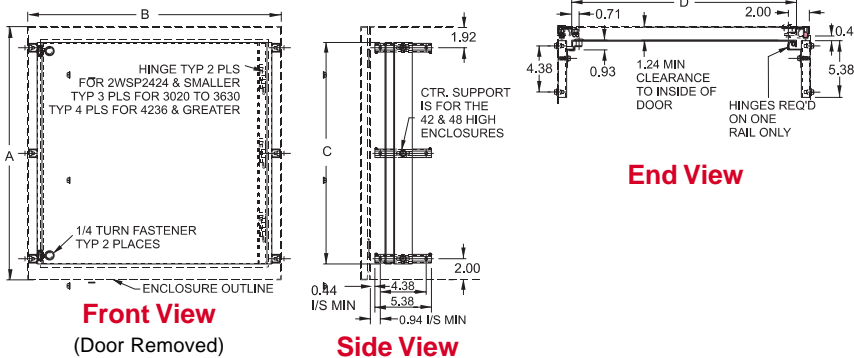

Part No.	A	B	C	D
2WSP1212	12	12	9	9.29
2WSP1612	16	12	13	9.29
2WSP1616	16	16	13	13.29
2WSP1620	16	20	13	17.29
2WSP2016	20	16	17	13.29
2WSP2020	20	20	17	17.29
2WSP2024	20	24	17	21.29
2WSP2416	24	16	21	13.29
2WSP2420	24	20	21	17.29
2WSP2424	24	24	21	21.29
2WSP3020	30	20	27	17.29
2WSP3024	30	24	27	21.29
2WSP3030	30	30	27	27.29
2WSP3624	36	24	33	21.29
2WSP3630	36	30	33	27.29
2WSP4236	42	36	39	33.29
2WSP4824	48	24	45	21.29
2WSP4836	48	36	45	33.29

For sizing, refer to master selection table...see page 46.

Swing Frame

- Provides 19" or 24" rack mounting with full EIA spacing (punched holes).
- Hinges allow easy equipment access.
- Slotted quarter turn latches provide closure.
- Adding optional locking quarter turn latches (**EQTRL**...see page 45) provides added security.
- Complete with 4-6" depth adjustment channels.
- Order package of 25 clip nuts separately (Part No. **1421N25**...see page 381).
- Hardware kit maintains UL, CSA and NEMA ratings when field installed.
- Finished in black.

Part No.	A	B	C	D	E	Rack Mt.
2WSF2024	20	24	17	21.29	9	19"
2WSF2424	24	24	21	21.29	11	19"
2WSF3024	30	24	27	21.29	15	19"
2WSF3030	30	30	27	27.29	15	24"
2WSF3624	36	24	33	21.29	17	19"
2WSF3630	36	30	33	27.29	17	24"
2WSF4824	48	24	45	21.29	25	19"

For sizing, refer to master selection table...see page 46.

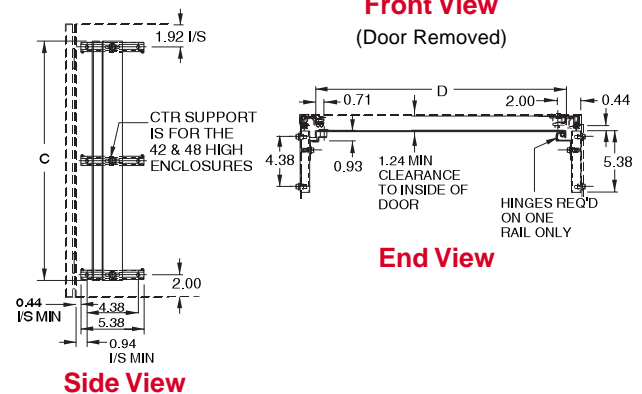
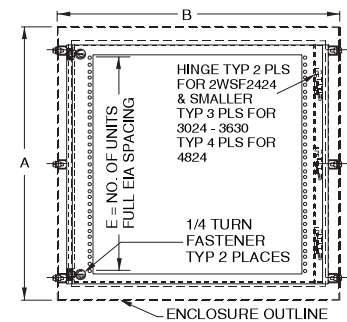

Series 2000- NEMA 4

Accessories

Industrial Enclosures
Wallmount Enclosures

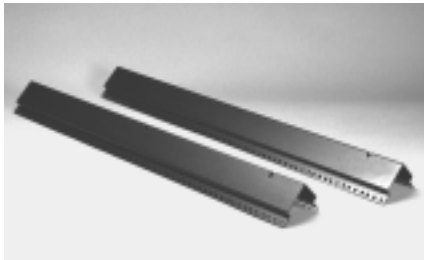

Fixed Rack Mounting Kit

- Formed 14 gauge steel.
- Reversible angles provide for mounting of 19" or 24" rack equipment.
- 24" overall width enclosure allows 19" mounting, 30" overall width enclosure allows 19 or 24" mounting.
- 0.28" diameter holes with standard RS-310-D spacing.
- Field installable - no drilling required.
- Finished in black.

Part No.	A	B	C	D
2FR20	17.50	3.00	—	2
2FR24	21.00	2.75	—	2
2FR30	28.00	3.25	—	3
2FR36	33.25	2.88	—	3
2FR48	45.50	3.00	13.67	4

Part No. reflects overall height of enclosure.

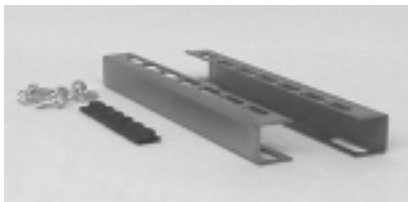
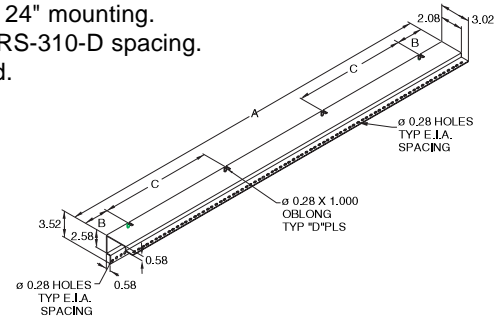

DIN Rail Mounting Kit

- Field installable.
- Mounts directly to panel collar studs (panel not required).
- Accepts optional DIN rails (see below).
- DIN rails available separately.
- Finished in black.

Part No.	A	B	C
2DMK12	10	1.25	7
2DMK16	14	0.75	11
2DMK20	18	0.88	14
2DMK24	22	1.00	17
2DMK30	28	0.88	22

For sizing, refer to master selection table...see page 46.

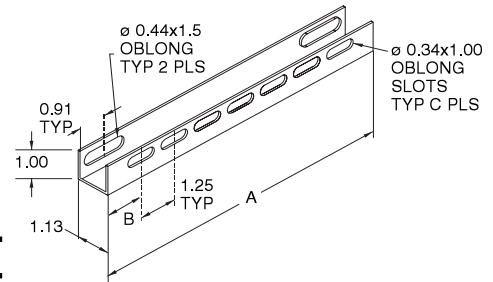

DIN Rails

- Field installable.
- Includes a set of 3 plated rails.
- Available in 3 industry standard profiles - DIN 1, DIN 3, and GENELEC.
- DIN rail mounting kit required for installation (see above).
- Rails have a 0.28 x 1.25 oblong slot on each end.
- Finished in black.

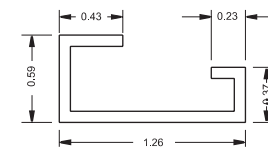

Asymmetric DIN 1 Profile

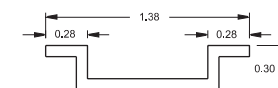

Symmetric DIN 3 Profile

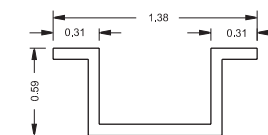

GENELEC Profile

Asymmetric Din 1 Profile Part No.	Symmetric Din 3 Profile Part No.	Cenelec Profile Part No.	Length
2D1K12	2D2K12	2DCK12	9.25
2D1K16	2D2K16	2DCK16	13.25
2D1K20	2D2K20	2DCK20	17.25
2D1K24	2D2K24	2DCK24	21.25
2D1K30	2D2K30	2DCK30	27.25

For sizing, refer to master selection table...see page 46.



Quarter Turn Inserts and Keys

- Field installable inserts replace standard slot.
- Available in 7mm square and triangle formats, as well as slotted.
- Square and triangle inserts provide extra security since standard screw drivers cannot open.
- Keys sold separately from inserts.
- Maintains NEMA, UL and CSA 12, 4 and 4X ratings.

Part No.	Description
2SQI7	7mm square insert, black
2SQK7	7mm square key, fits 2SQI7
2TRI7	7mm triangle insert, black
2TRK7	7mm triangle key, fits 2TRI7
2SLI	Slotted insert, black



Replacement Quarter Turn Assemblies

- Field installable.
- Interchangeable with standard quarter turn latches.
- Maintains NEMA, UL and CSA ratings as noted.

Part No.	Description	Material	NEMA Rating
EQTRL¹	Locking Qtr Turn	Zinc Die/Chrome	n/a (internal use only)
2QTR	Slotted Qtr Turn	Zinc Die/Black	12, 4
2SSQTR	Slotted Qtr Turn	Stainless steel	12, 4, 4X
2WKL	Wing knob lock	Zinc Die/Black	12, 4
2QPL	Padlockable quarter turn latch	Zinc Die/Black	12, 4

¹ For use with Swing Frame/Panel. ..see page 43. All others for use with enclosures.



Handles

- Field installable.
- Interchangeable with standard quarter turn latches.
- Maintain NEMA, UL and CSA ratings as noted.

Part No.	Description	Material	NEMA Rating
EHTL	Locking T Handle	Zinc Die/Black	12, 4
EHLL	Locking L Handle	Zinc Die/Black	12, 4
EHLPL	Padlockable L Handle	Zinc Die/Chrome	12
EHLPLSS	Padlockable L Handle	Stainless Steel	12, 4, 4X
EHLNLSS	Non Locking L Handle	Stainless Steel	12, 4, 4X

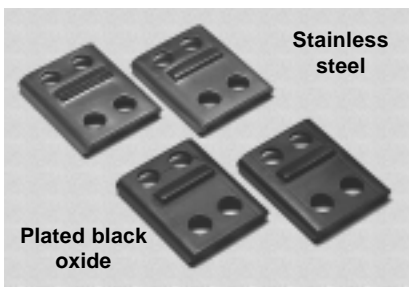

Series 2000 Mounting Foot Kit

- Field installable.
- Available in plated black oxide and stainless steel.
- Packaged in quantities of four.
- Maintains NEMA, UL and CSA Type rating as shown.

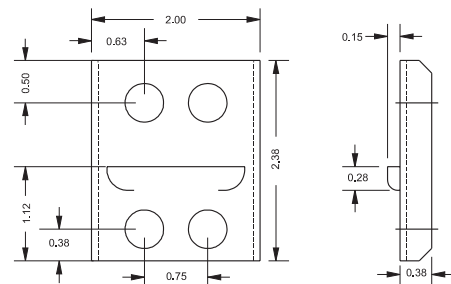

Part No.	Material	For Nema Rating
2ZPMF	Steel black oxide	NEMA 12,13
2SSMF	Stainless steel	NEMA 3R, 4, 4X, 12, 13

Series 2000- NEMA 4

Master Selection Table

NEMA 4 Part No.	Enclosure Dim.			Inner Panel	Swing Frame Kits	Swing Panel Kits	Fixed Rack Mtg. Kit	Window Doors	DIN Rail Mounting Kit	Din Rails (Set of 3)		
	A	B	C							1	3	CENELEC
2P12126	12	12	6	18P0909	—	2WSP1212	—	2RW1212	2DMK12	2D1K12	2D2K12	2DCK12
2P16126	16	12	6	18P1309	—	2WSP1612	—	2RW1612	2DMK16	2D1K12	2D2K12	2DCK12
2P16166	16	16	6	18P1313	—	2WSP1616	—	2RW1616	2DMK16	2D1K16	2D2K16	2DCK16
2P20166	20	16	6	18P1713	—	2WSP2016	—	2RW2016	2DMK20	2D1K16	2D2K16	2DCK16
2P20206	20	20	6	18P1717	—	2WSP2020	—	2RW2020	2DMK20	2D1K20	2D2K20	2DCK20
2P20168	20	16	8	18P1713	—	2WSP2016	—	2RW2016	2DMK20	2D1K16	2D2K16	2DCK16
2P24168	24	16	8	18P2113	—	2WSP2416	—	2RW2416	2DMK24	2D1K16	2D2K16	2DCK16
2P16208	16	20	8	18P1713	—	2WSP1620	—	2RW1620	2DMK16	2D1K20	2D2K20	2DCK20
2P20208	20	20	8	18P1717	—	2WSP2020	—	2RW2020	2DMK20	2D1K20	2D2K20	2DCK20
2P24208	24	20	8	18P2117	—	2WSP2420	—	2RW2420	2DMK24	2D1K20	2D2K20	2DCK20
2P30208	30	20	8	18P2717	—	2WSP3020	—	2RW3020	2DMK30	2D1K20	2D2K20	2DCK20
2P20248	20	24	8	18P2117	2WSF2024	2WSP2024	2FR20	2RW2024	2DMK20	2D1K24	2D2K24	2DCK24
2P24248	24	24	8	18P2121	2WSF2424	2WSP2424	2FR24	2RW2424	2DMK24	2D1K24	2D2K24	2DCK24
2P30248	30	24	8	18P2721	2WSF3024	2WSP3024	2FR30	2RW3024	2DMK30	2D1K24	2D2K24	2DCK24
2P36248	36	24	8	18P3321	2WSF3624	2WSP3624	2FR36	2RW3624	—	—	—	—
2P30308	30	30	8	18P2727	2WSF3030	2WSP3030	2FR30	2RW3030	2DMK30	2D1K30	2D2K30	2DCK30
2P36308	36	30	8	18P3327	2WSF3630	2WSP3630	2FR36	2RW3630	—	—	—	—
2P242412	24	24	12	18P2121	2WSF2424	2WSP2424	2FR24	2RW2424	2DMK24	2D1K24	2D2K24	2DCK24
2P302412	30	24	12	18P2721	2WSF3024	2WSP3024	2FR30	2RW3024	2DMK30	2D1K24	2D2K24	2DCK24
2P482412	48	24	12	18P4521	2WSF4824	2WSP4824	2FR20	2RW4824	—	—	—	—
2P363012	36	30	12	18P3327	2WSF3630	2WSP3630	2FR36	2RW3630	—	—	—	—
2P423612	42	36	12	18P3933	—	2WSP4236	—	2RW4236	—	—	—	—
2P483612	48	36	12	18P4533	—	2WSP4836	—	2RW4836	—	—	—	—
2P242416	24	24	16	18P2121	2WSF2424	2WSP2424	2FR24	2RW2424	2DMK24	2D1K24	2D2K24	2DCK24
2P363016	36	30	16	18P3327	2WSF3630	2WSP3630	2FR36	2RW3630	—	—	—	—
2P483616	48	36	16	18P4533	—	2WSP4836	—	2RW4836	—	—	—	—

Industrial Enclosures
 Wallmount Enclosures

1418 Series Single Door Enclosures - NEMA 12, 13

Continuous Hinge, Clamped Cover

Inner Panel Included



Industrial Enclosures
Wallmount Enclosures

Application

- Designed to house electrical, electronic, hydraulic or pneumatic controls and instruments.
- Provides a degree of protection from falling dirt, dust, oil and water.

Standards

- UL 508 Type 12 and 13
- CSA Type 12 and 13
- Complies with**
 - NEMA Type 12 and 13
 - JIC EGP-1-1967 unless marked¹
 - IEC 529, IP65

Construction

- Formed 14 gauge steel bodies and doors.
- Smooth, continuously welded seams without knockouts, cutouts or holes.
- Door and body stiffeners are provided in the larger enclosures for extra rigidity.
- Welded brackets provide for enclosure mounting.
- Formed lip on door and enclosure exclude flowing liquids and contaminants.
- Continuously hinged door may be removed by pulling the hinge pin.
- Door is secured with easily operated stainless steel clamps.
- Provision for padlocking.
- Oil resistant gaskets are permanently secured and mechanically retained.
- A removable 12 gauge inner panel is included.
- Collar studs are provided for mounting inner panels.
- A bonding stud is provided on the door and a grounding stud is provided in the enclosure.
- A literature pocket is provided for the inside of the door.

Finish

- Cover and enclosure are finished in recoatable smooth ANSI/ASA 61 gray powder coating on the outside, with white powder coating on the inside.
- Removable inner panel is finished in white powder coating.

Accessories

- Additional inner panels...see page **384**
- Air conditioners...see page **348-357**
- Blowers...see page **359**
- Breather kits...see page **374**
- Door clamping hardware...see page **378**
- Door stop kits...see page **393**
- Drip shield kits...see page **393**
- Enclosure stabilizers...see page **397**
- Filter fans...see page **360-367**
- Floor stand kits...see page **394**
- Heaters...see page **369-371**
- Lock kit...see page **379**
- Louvered ventilating plates...see page **396**
- Quick release clamp...see page **378**
- Terminal kit assemblies...see page **386**
- Thermostats...see page **374**
- Window kits...see page **391**

Part No.	Panel Size			Centers		Ship Wt. lbs
	A	B	C	D	E	
1418A6 ²	12	24	6	9	21	34
1418B6 ²	16	12	6	13	9	26
1418G6 ²	16	16	6	13	13	32
1418CR6 ²	16	20	6	13	17	38
1418CA6 ²	20	12	6	17	9	32
1418C6 ²	20	16	6	17	13	38
1418D6 ²	20	20	6	17	17	48
1418ER6	20	24	6	17	21	54
1418AR6 ²	24	12	6	21	9	36
1418H6	24	16	6	21	13	46
1418E6	24	20	6	21	17	54
1418J6	24	24	6	21	21	62
1418FG6	30	16	6	27	13	56
1418F6	30	20	6	27	17	66
1418K6	30	24	6	27	21	76
1418L6	36	24	6	33	21	91
1418M6	36	30	6	33	27	114
1418A8 ²	12	24	8	9	21	38
1418B8 ²	16	12	8	13	9	28
1418G8 ²	16	16	8	13	13	34
1418CR8 ²	16	20	8	13	17	43
1418CA8 ²	20	12	8	17	9	35
1418C8 ²	20	16	8	17	13	40

Part No.	Panel Size			Centers		Ship Wt. lbs
	A	B	C	D	E	
1418D8 ²	20	20	8	17	17	48
1418ER8	20	24	8	17	21	61
1418AR8	24	12	8	21	9	40
1418H8	24	16	8	21	13	50
1418E8	24	20	8	21	17	58
1418J8	24	24	8	21	21	68
1418KR8	24	30	8	21	27	82
1418KA8	30	12	8	27	9	50
1418KG8	30	16	8	27	13	60
1418F8	30	20	8	27	17	70
1418K8	30	24	8	27	21	82
1418KK8	30	30	8	27	27	102
1418MR8	30	36	8	27	33	124
1418L8	36	24	8	33	21	96
1418M8	36	30	8	33	27	120
1418LL8 ¹	36	36	8	33	33	142
1418N8	42	24	8	39	21	110
1418O8 ¹	42	30	8	39	27	132
1418P8 ¹	42	36	8	39	33	182
1418Q8	48	24	8	45	21	122
1418R8 ¹	48	30	8	45	27	173
1418S8 ¹	48	36	8	45	33	201
1418T8 ¹	60	36	8	57	33	246

¹ Does not meet JIC requirements

² Flat Panel

¹ Does not meet JIC requirements

² Flat Panel

Technical references and DXF downloads available at www.hammg.com

All dimensions in inches unless specified otherwise

1418 Series Single Door Enclosures - NEMA 12, 13

Continuous Hinge, Clamped Cover

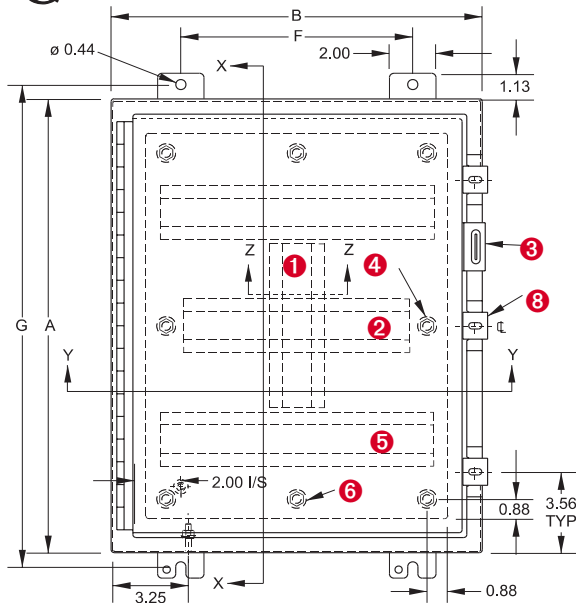

Front View

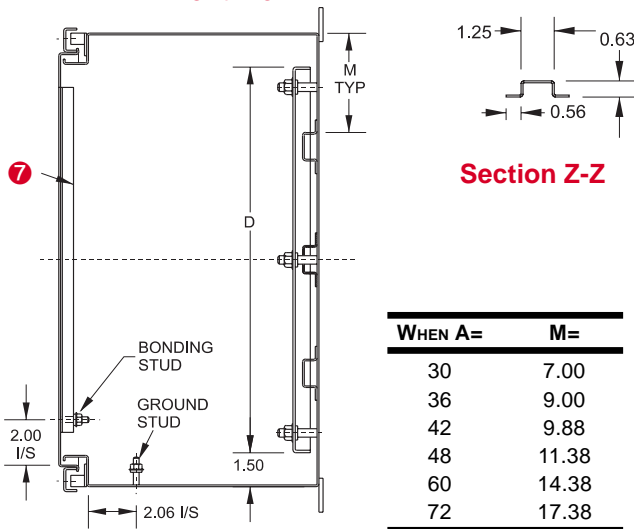

Side View

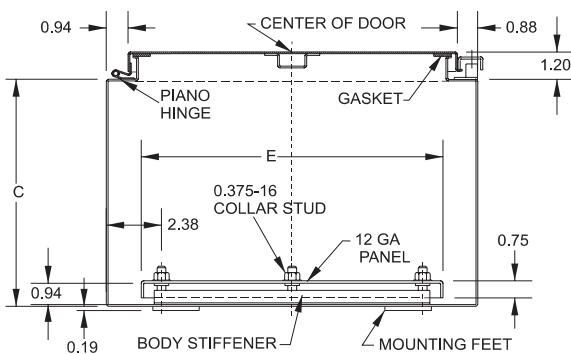

Top View

- 1 Vertical stiffener required on KK, M, MR and LL only.
- 2 Omit center body stiffener if A is less than 41".
- 3 Padlocking hasp and staple.
- 4 Omit 2 middle studs if A is less than 31".
- 5 Omit body stiffeners if A or B is less than 29".
- 6 Omit 2 middle studs if B is less than 31".
- 7 Omit door stiffener if A or B is less than 31" except if AxB is 42"x30", 48"x30" or 72"x30".
- 8 Omit if A is less than 48".

Part No.	Panel Size					Centers		Ship Wt. lbs
	A	B	C	D	E	F	G	
1418B10 ²	16	12	10	13	9	9.5	17.25	30
1418C10 ²	20	16	10	17	13	10.0	21.25	44
1418D10 ²	20	20	10	17	17	14.0	21.25	52
1418AR10 ²	24	12	10	21	9	9.5	25.25	42
1418E10	24	20	10	21	17	14.0	25.25	64
1418J10	24	24	10	21	21	18.0	25.25	73
1418F10	30	20	10	27	17	14.0	31.25	76
1418K10	30	24	10	27	21	18.0	31.25	86
1418L10	36	24	10	33	21	18.0	37.25	105
1418M10	36	30	10	33	27	24.0	37.25	124
1418O10 ¹	42	30	10	39	27	24.0	43.25	140
1418P10 ¹	42	36	10	39	33	30.0	43.25	192
1418R10 ¹	48	30	10	45	27	24.0	49.25	162
1418S10 ¹	48	36	10	45	33	30.0	49.25	208
1418T10 ¹	60	36	10	57	33	30.0	61.25	258
1418C12 ²	20	16	12	17	13	10.0	21.25	48
1418E12	24	20	12	21	17	14.0	25.25	68
1418J12	24	24	12	21	21	18.0	25.25	76
1418K12	30	24	12	27	21	18.0	31.25	90
1418KK12	30	30	12	27	27	24.0	31.25	114
1418L12	36	24	12	33	21	18.0	37.25	108
1418M12	36	30	12	33	27	24.0	37.25	132
1418LL12 ¹	36	36	12	33	33	30.0	37.25	156
1418O12 ¹	42	30	12	39	27	24.0	43.25	150
1418P12 ¹	42	36	12	39	33	30.0	43.25	198
1418S12 ¹	48	36	12	45	33	30.0	49.25	222
1418T12 ¹	60	36	12	57	33	30.0	61.25	264
1418U12 ¹	72	30	12	69	27	24.0	73.25	272
1418V12	72	36	12	69	33	30.0	73.25	312
1418E16	24	20	16	21	17	14.0	25.25	74
1418J16	24	24	16	21	21	18.0	25.25	86
1418K16	30	24	16	27	21	18.0	31.25	102
1418M16	36	30	16	33	27	24.0	37.25	140
1418P16 ¹	42	36	16	39	33	30.0	43.25	214
1418S16 ¹	48	36	16	45	33	30.0	49.25	238
1418T16 ¹	60	36	16	57	33	30.0	61.25	290
1418U16 ¹	72	30	16	69	27	24.0	73.25	290
1418K20	30	24	20	27	21	18.0	31.25	112
1418M20	36	30	20	33	27	24.0	37.25	152
1418S20 ¹	48	36	20	45	33	30.0	49.25	256
1418T20 ¹	60	36	20	57	33	30.0	61.25	300
1418U20 ¹	72	30	20	69	27	24.0	73.25	308
1418K24	30	24	24	27	21	18.0	31.25	142
1418U24 ¹	72	30	24	69	27	24.0	73.25	332

¹ Does not meet JIC requirements

² Flat Panel

Industrial Enclosures
Wallmount Enclosures

1418 N4 Series Single Door Enclosures - NEMA 12, 4

Continuous Hinge, Clamped Cover

Industrial Enclosures
Wallmount Enclosures



**Inner
Panel
Included**



Application

- Designed for use as instrument enclosures, electric, hydraulic or pneumatic control housings, electrical junction boxes or terminal wiring enclosures.
- Provides protection where equipment may be hosed down or otherwise be very wet, or in outdoor applications for full weather protection.

Standards

- UL 508 Type 3R, 12, 4
- CSA Type 3R, 12, 4
- **Complies with**
 - NEMA Type 3R, 4, 12 and 13
 - JIC EGP-1-1967 unless marked¹
 - IEC 529, IP66

Construction

- Formed 14 gauge steel bodies and doors.
- Smooth, continuously welded seams without knockouts, cutouts or holes.
- Door and body stiffeners are provided in the larger enclosures for extra rigidity.
- Welded brackets provide for enclosure mounting.
- Formed lip on door and enclosure exclude flowing liquids and contaminants.
- Stainless steel continuous hinge on door may be removed by pulling the stainless steel hinge pin.
- Door is secured with easily operated stainless steel clamps.
- Provision for padlocking.
- Oil resistant gaskets are permanently secured and mechanically retained.
- A removable 12 gauge inner panel is included.
- Collar studs are provided for mounting inner panels.
- A bonding stud is provided on the door and a grounding stud is provided in the enclosure.
- A literature pocket is provided for the inside of the door.

Finish

- Cover and enclosure are finished in recoatable smooth ANSI/ASA 61 gray powder coating.
- Removable inner panel is finished in white powder coating.

Accessories

- Additional inner panels...see page **384**
- Air conditioners...see page **348-357**
- Blowers...see page **359**
- Breather kits...see page **374**
- Door clamping hardware...see page **378**
- Door stop kits...see page **393**
- Drip shield kits...see page **393**
- Enclosure stabilizers...see page **397**
- Filter fans...see page **360-367**
- Floor stand kits...see page **394**
- Heaters...see page **369-371**
- Lock kit...see page **379**
- Louvered ventilating plates...see page **396**
- Quick release clamp...see page **378**
- Terminal kit assemblies...see page **386**
- Thermostats...see page **374**
- Window kits...see page **391**

1418 N4 Series Single Door Enclosures - NEMA 12, 4

Continuous Hinge, Clamped Cover

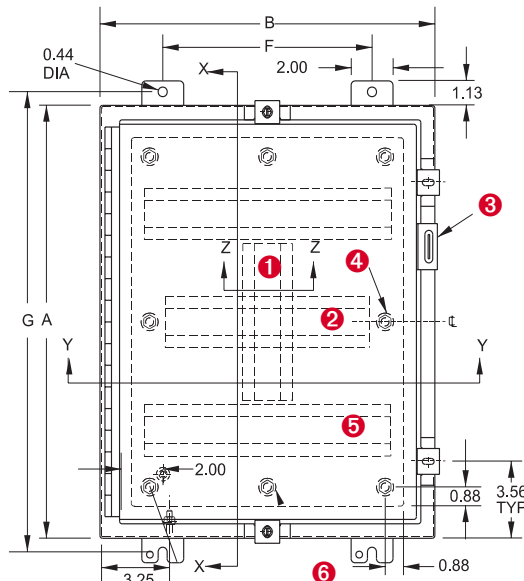

Front View

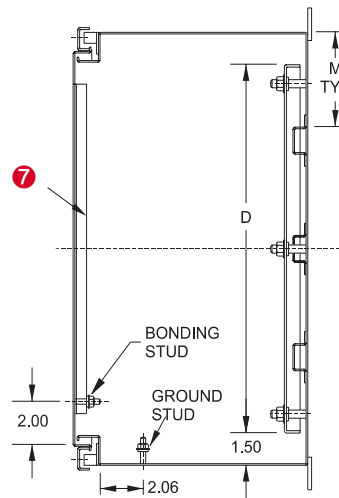

Side View

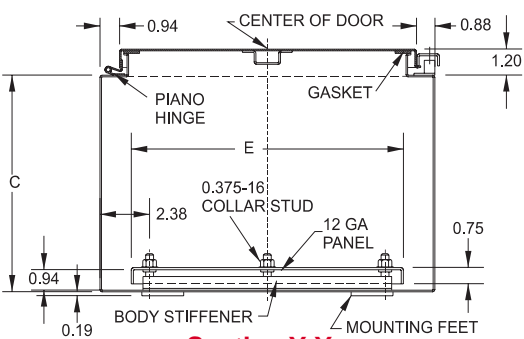

Section Y-Y

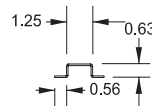

Section Z-Z

- ❶ Vertical stiffener required on KK and M only.
- ❷ Omit center body stiffener if A is less than 41".
- ❸ Padlocking hasp and staple.
- ❹ Omit 2 middle studs if A is less than 31".
- ❺ Omit body stiffeners if A or B is less than 29".
- ❻ Omit 2 middle studs if B is less than 31".
- ❼ Omit door stiffener if A or B is less than 31" except if AxB is 42"x30" or 48"x30".

When A=	M=
30	7.00
36	9.00
42	9.88
48	11.38
60	14.38

Literature pocket supplied loose.
Number of door clamps varies to enclosure size.

Part No.	Panel Size			Mtg. Centers				Ship Wt. lbs.
	A	B	C	D	E	F	G	
1418N4B6 ²	16	12	6	13	9	9.5	17.25	27
1418N4G6 ²	16	16	6	13	13	10.0	17.25	34
1418N4CR6 ²	16	20	6	13	17	14.0	17.25	41
1418N4C6 ²	20	16	6	17	13	10.0	21.25	40
1418N4D6 ²	20	20	6	17	17	14.0	21.25	40
1418N4AR6	24	12	6	21	9	9.5	25.25	41
1418N4H6	24	16	6	21	13	10.0	25.25	42
1418N4E6	24	20	6	21	17	14.0	25.25	56
1418N4J6	24	24	6	21	21	18.0	25.25	65
1418N4F6	30	20	6	27	17	14.0	31.25	70
1418N4K6	30	24	6	27	21	18.0	31.25	80
1418N4L6	36	24	6	33	21	18.0	37.25	91
1418N4B8 ²	16	12	8	13	9	9.5	17.25	29
1418N4C8 ²	20	16	8	17	13	10.0	21.25	44
1418N4D8 ²	20	20	8	17	17	14.0	21.25	51
1418N4ER8	20	24	8	17	21	18.0	21.25	55
1418N4E8	24	20	8	21	17	14.0	25.25	60
1418N4J8	24	24	8	21	21	18.0	25.25	70
1418N4KR8	24	30	8	21	27	24.0	25.25	74
1418N4F8	30	20	8	27	17	14.0	31.25	79
1418N4K8	30	24	8	27	21	18.0	31.25	88
1418N4KK8	30	30	8	27	27	24.0	31.25	106
1418N4L8	36	24	8	33	21	18.0	37.25	101

Part No.	Panel Size			Mtg. Centers				Ship Wt. lbs.
	A	B	C	D	E	F	G	
1418N4M8	36	30	8	33	27	24	37.25	121
1418N4O8 ¹	42	30	8	39	27	24	43.25	132
1418N4P8 ¹	42	36	8	39	33	30	43.25	177
1418N4S8 ¹	48	36	8	45	33	30	49.25	207
1418N4T8 ¹	60	36	8	57	33	30	61.25	245
1418N4C10 ²	20	16	10	17	13	10	21.25	47
1418N4E10	24	20	10	21	17	14	25.25	66
1418N4K10	30	24	10	27	21	18	31.25	91
1418N4M10	36	30	10	33	27	24	37.25	125
1418N4R10 ¹	48	30	10	45	27	24	49.25	175
1418N4S10 ¹	48	36	10	45	33	30	49.25	183
1418N4T10 ¹	60	36	10	57	33	30	61.25	252
1418N4E12	24	20	12	21	17	14	25.25	71
1418N4K12	30	24	12	27	21	18	31.25	95
1418N4L12	36	24	12	33	21	18	37.25	106
1418N4M12	36	30	12	33	27	24	37.25	136
1418N4P12 ¹	42	36	12	39	33	30	43.25	202
1418N4S12 ¹	48	36	12	45	33	30	49.25	225
1418N4K16	30	24	16	27	21	18	31.25	100
1418N4M16	36	30	16	33	27	24	37.25	149
1418N4S16 ¹	48	36	16	45	33	30	49.25	290
1418N4T16 ¹	60	36	16	57	33	30	61.25	232

¹ Does not meet JIC requirements ² Flat Panel

¹ Does not meet JIC requirements ² Flat Panel

1422 Series Two Door Wallmount Enclosures - NEMA 12

Continuous Hinge



Application

- Designed to house electrical, electronic, hydraulic or pneumatic controls and instruments.
- Provides a degree of protection from falling dirt, dust, oil and water.

Standards

- UL 508 Type 12
- CSA Type 12
- **Complies with**
 - NEMA Type 12
 - IEC 529, IP65

Construction

- Enclosures are formed 12 or 14 gauge steel, as noted.
- Smooth, continuously welded seams without knockouts, cutouts or holes.
- Body stiffeners are provided in enclosures 30" high or more for extra rigidity.
- Welded brackets provide for enclosure mounting.
- Gasketed overlapping doors eliminate the need for a center post.
- Continuously hinged doors may be removed by pulling the hinge pin.
- Doors are secured with a three point latch and operated with a key locking automotive type handle.
- Latch rods are equipped with rollers for easier door closing.
- Oil resistant gaskets are permanently secured and mechanically retained.
- A removable 10 gauge inner panel is included in enclosures as noted on chart at right. Smaller sizes include a 12 gauge inner panel.
- Collar studs are provided for mounting inner panels.
- A grounding stud is provided in the enclosure and a bonding stud is provided on the door.
- A literature pocket is provided for the inside of the door.

Finish

- Cover and enclosure are phosphatized and finished in recoatable smooth ANSI/ASA 61 gray powder coating on the outside, with white powder coating on the inside.
- Removable inner panel is finished in white powder coating.

Accessories

- Additional inner panels...see page **384**
- Air conditioners...see page **348-357**
- Blowers...see page **359**
- Breather kits...see page **374**
- Door stop kits...see page **393**
- Drip shield kits...see page **393**
- Enclosure stabilizers...see page **397**
- Filter fans...see page **360-367**
- Floor stand kits...see page **394**
- Heaters...see page **369-371**
- Light kit...see page **393**
- Louvered ventilating plates...see page **396**
- Thermostats...see page **374**
- Window kits...see page **391**

1422 Series Two Door Wallmount Enclosures - NEMA 12

Continuous Hinge

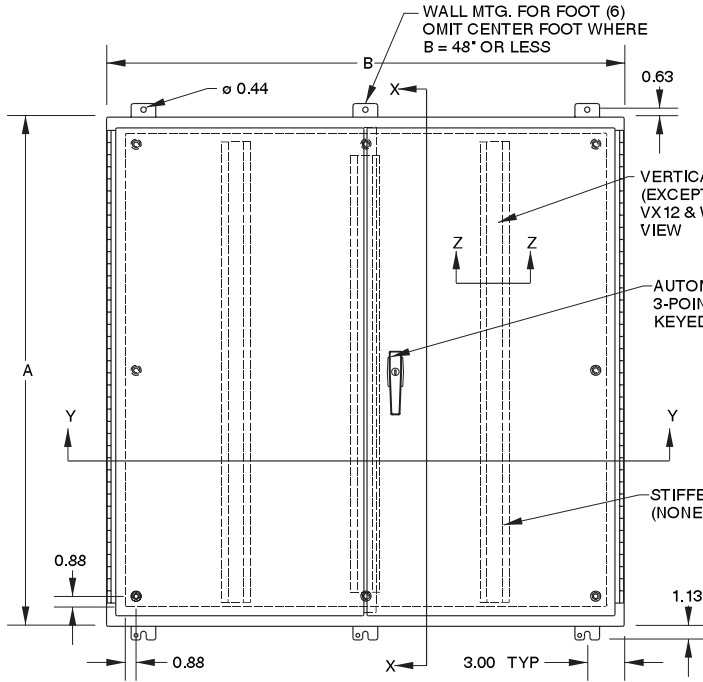

Front View

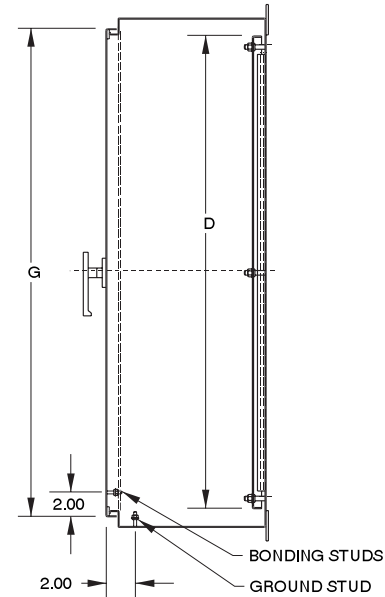

Side View

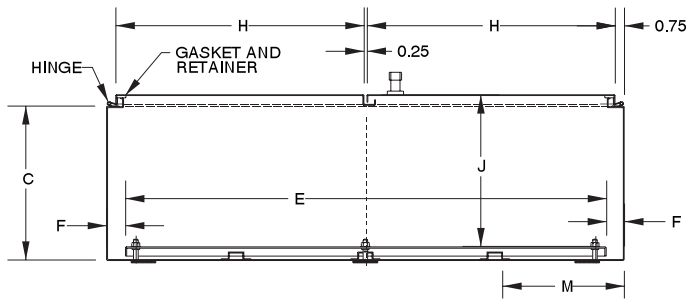

Section Y-Y

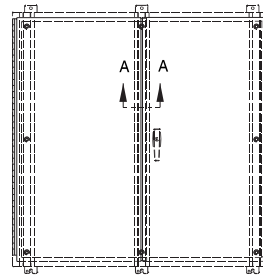

Horizontal Stiffener Layout

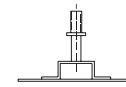

Section A-A

1422VX12 & 1422WW12

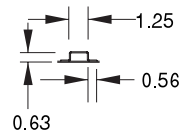

Section Z-Z

(Except 1422VX12 & 1422WW12)

When B=	M=
42	9.88
48	11.38
60	14.38

Part No.	A	B	C	Body Gauge	Panel Gauge	Panel Size D	E	F	G	H	J	Ship Wt. lbs.
1422P8	24	42	8.00	14	12	21	39	1.5	22.25	20.13	7.96	79
1422PW8	24	48	8.00	14	12	21	45	1.5	22.25	23.13	7.96	92
1422P10	24	42	10.00	14	12	21	39	1.5	22.25	20.13	9.96	101
1422R10	30	42	10.00	14	12	27	39	1.5	28.25	20.13	9.96	112
1422RW10	30	48	10.00	14	12	27	45	1.5	28.25	23.13	9.96	115
1422RX10	30	60	10.00	14	12	27	57	1.5	28.25	29.13	9.96	142
1422UV12	36	42	12.00	14	12	33	39	1.5	34.25	20.13	11.96	134
1422UW12	36	48	12.00	14	12	33	45	1.5	34.25	23.13	11.96	139
1422UX12	36	60	12.00	14	12	33	57	1.5	34.25	29.13	11.96	181
1422VV12	42	42	12.00	14	12	39	39	1.5	40.25	20.13	11.96	152
1422VW12	42	48	12.00	14	12	39	45	1.5	40.25	23.13	11.96	161
1422VX12	42.13	60.06	12.69	12	10	38	56	2.0	40.25	29.13	11.96	202
1422WW12	48.13	48.06	12.69	12	10	44	44	2.0	46.25	23.13	11.96	181

Technical references and DXF downloads available at www.hammfg.com

All dimensions in inches unless specified otherwise

Quality Enclosures. Service Excellence.

1422 Series Two Door Floormount Enclosures - NEMA 12

Continuous Hinge



**Inner
Panel
Included**



Application

- Designed to house electrical, electronic, hydraulic or pneumatic controls and instruments.
- Provides a degree of protection from falling dirt, dust, oil and water.

Standards

- UL 508 Type 12
- CSA Type 12
- **Complies with**
 - NEMA Type 12
 - IEC 529, IP65

Construction

- Enclosures 54" high or less are formed 14 gauge steel.
- Enclosures 60" high are formed 12 gauge steel.
- Enclosures 72" high are formed 12 gauge steel with a 10 gauge steel back.
- Smooth, continuously welded seams without knockouts, cutouts or holes.
- Body stiffeners are provided in enclosures for extra rigidity.
- Heavy duty lifting eyebolts are provided with reinforced support angles.

- 12" floor stands are welded to the enclosure.
- Gasketed overlapping doors eliminate the need for a center post.
- Continuously hinged doors may be removed by pulling the hinge pin.
- Doors are secured with a three point latch and operated with a key locking automotive type handle.
- Latch rods are equipped with rollers for easier door closing.
- Oil resistant gaskets are permanently secured and mechanically retained.
- A removable 10 gauge inner panel is included in enclosures 60" and larger. Smaller sizes include a 12 gauge inner panel.
- Panel supports are provided in enclosures 60" and larger for easy panel installation.
- Collar studs are provided for mounting inner panels.
- A grounding stud is provided in the enclosure for each door and a bonding stud is provided on the door.
- A literature pocket is provided for the inside of the door.

Finish

- Cover and enclosure are phosphatized and finished in recoatable smooth ANSI/ASA 61 gray powder coating on the outside, with white powder coating on the inside.
- Removable inner panel is finished in white powder coating.

Accessories

- Additional inner panels...see page **385**
- Air conditioners...see page **348-357**
- Blowers...see page **359**
- Breather kits...see page **374**
- Door stop kits...see page **393**
- Drip shield kits...see page **393**
- Enclosure stabilizers...see page **397**
- Filter fans...see page **360-367**
- Floor stand kits...see page **394**
- Heaters...see page **369-371**
- Light kit...see page **393**
- Louvered ventilating plates...see page **396**
- Thermostats...see page **374**
- Window kits...see page **391**

1422 Series Two Door Floormount Enclosures - NEMA 12

Continuous Hinge

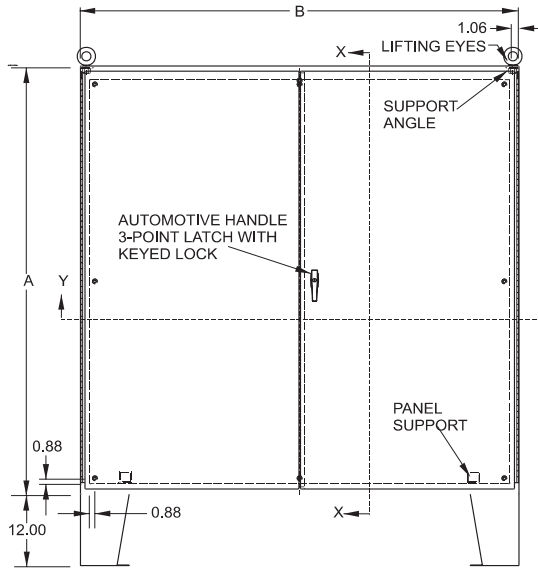

Front View

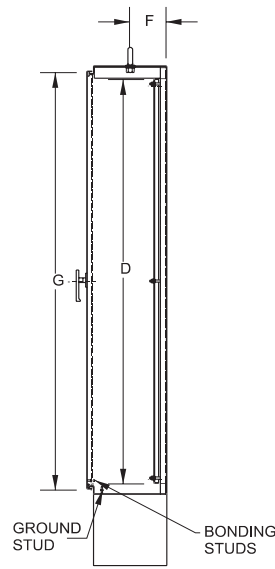

Section X-X

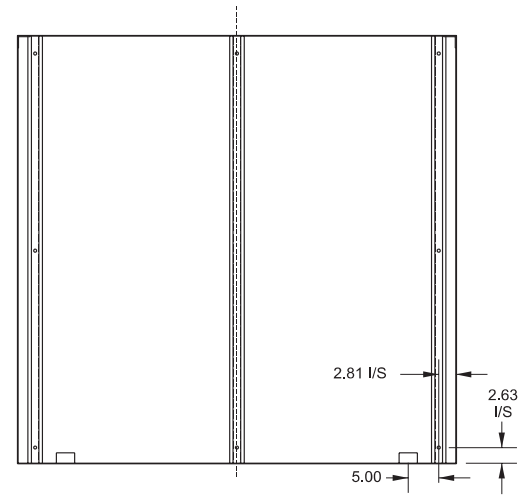

Stiffener Layout

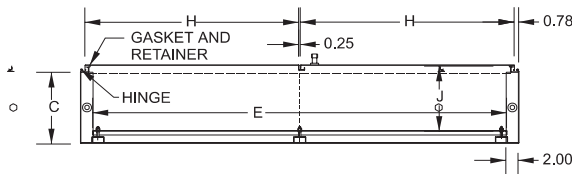

Section Y-Y

With Feet Part No.	Without Feet Part No.	A	B	C	Body Gauge	Panel Gauge	Panel Size D	Panel Size E	F	G	H	J	Ship Wt. lbs.
1422A8F	1422A8	54.13	42.06	8.69	14	12	50	38	4.03	52.25	20.13	8.96	275
1422B8F	1422B8	60.13	48.06	8.69	12	10	56	44	4.03	58.25	23.13	7.96	450
1422B10F	1422B10	60.13	48.06	10.69	12	10	56	44	5.03	58.25	23.13	9.96	475
1422D10F	1422D10	60.13	60.06	10.69	12	10	56	56	5.03	58.25	29.13	9.96	550
1422E10F	1422E10	72.13	60.06	10.69	12	10	68	56	5.03	70.25	29.13	9.96	625
1422F10F	1422F10	72.13	72.06	10.69	12	10	68	68	5.03	70.25	35.13	9.96	740
1422B12F	1422B12	60.13	48.06	12.69	12	10	56	44	5.03	58.25	23.13	11.96	491
1422D12F	1422D12	60.13	60.06	12.69	12	10	56	56	5.03	58.25	29.13	11.96	567
1422E12F	1422E12	72.13	60.06	12.69	12	10	68	56	5.03	70.25	29.13	11.96	645
1422F12F	1422F12	72.13	72.06	12.69	12	10	68	68	5.03	70.25	35.13	11.96	750
1422B16F	1422B16	60.13	48.06	16.69	12	10	56	44	8.03	58.25	23.13	15.96	520
1422D16F	1422D16	60.13	60.06	16.69	12	10	56	56	8.03	58.25	29.13	15.96	540
1422E16F	1422E16	72.13	60.06	16.69	12	10	68	56	8.03	70.25	29.13	15.96	740
1422F16F	1422F16	72.13	72.06	16.69	12	10	68	68	8.03	70.25	35.13	15.96	795
1422B20F	1422B20	60.13	48.06	20.69	12	10	56	44	10.03	58.25	23.13	19.96	506
1422E20F	1422E20	72.13	60.06	20.69	12	10	68	56	10.03	70.25	29.13	19.96	750
1422F20F	1422F20	72.13	72.06	20.69	12	10	68	68	10.03	70.25	35.13	19.96	885
1422B24F	1422B24	60.13	48.06	24.69	12	10	56	44	12.03	58.25	23.13	23.96	550
1422D24F	1422D24	60.13	60.06	24.69	12	10	56	56	12.03	58.25	29.13	23.96	660
1422E24F	1422E24	72.13	60.06	24.69	12	10	68	56	12.03	70.25	29.13	23.96	810
1422F24F	1422F24	72.13	72.06	24.69	12	10	68	68	12.03	70.25	35.13	23.96	945

1422 Series Two Door Floormount Enclosures - NEMA 12, 4

Continuous Hinge, Clamped Doors



Application

- Designed to house electrical, electronic, hydraulic or pneumatic controls and instruments.
- Provides protection where equipment may be hosed down or otherwise be very wet, or in outdoor applications for full weather protection.

Standards

- UL 508 Type 3R, 4 and 12
- CSA Type 3R, 4 and 12
- **Complies with**
 - NEMA Type 3R, 4 12 and 13
 - JIC EGP-1-1967
 - IEC 529, IP66

Construction

- Formed 12 gauge steel.
- Smooth, continuously welded seams without knockouts, cutouts or holes.
- Body stiffeners are provided in the larger enclosures for extra rigidity.
- Heavy duty lifting eyebolts are provided with reinforcing support angles.
- Center post is removable for easy installation of the inner panel.
- Formed lip on door and top of enclosure opening exclude flowing liquids and contaminants.
- Continuously hinged doors may be removed by pulling the stainless steel hinge pin.
- Doors are secured with heavy duty stainless steel clamps.
- Provision for padlocking.
- 12" floor stands are welded to the enclosure.
- Oil resistant gaskets are permanently secured and mechanically retained.
- A removable 10 gauge inner panel is included.
- Panel supports are provided for easy panel installation.
- Collar studs are provided for mounting inner panels.

- A bonding stud is provided on the door and a grounding stud is provided in the enclosure for each door.
- A literature pocket is provided for the inside of the door.

Finish

- Cover and enclosure are finished in recoatable smooth ANSI/ASA 61 gray powder coating.
- Removable white inner panel is finished in white powder coating.

Accessories

- Additional inner panels...see page **385**
- Air conditioners...see page **348-357**
- Blowers...see page **359**
- Breather kits...see page **374**
- Door stop kits...see page **393**
- Drip shield kits...see page **393**
- Enclosure stabilizers...see page **397**
- Filter fans...see page **360-367**
- Floor stand kits...see page **394**
- Heaters...see page **369-371**
- Light kit...see page **393**
- Louvered ventilating plates...see page **396**
- Thermostats...see page **374**
- Window kits...see page **391**

1422 Series Two Door Floormount Enclosures - NEMA 12, 4

Continuous Hinge, Clamped Doors

Industrial Enclosures
Floormount Enclosures

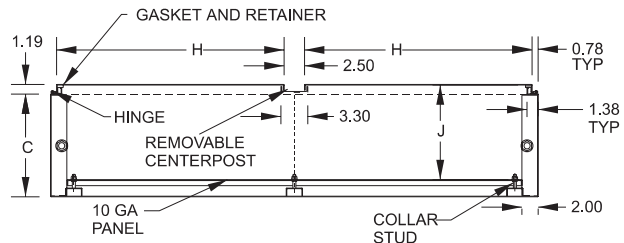
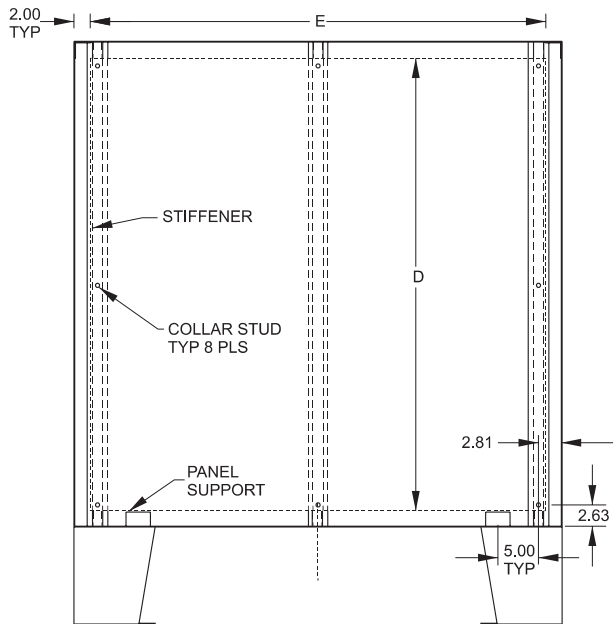
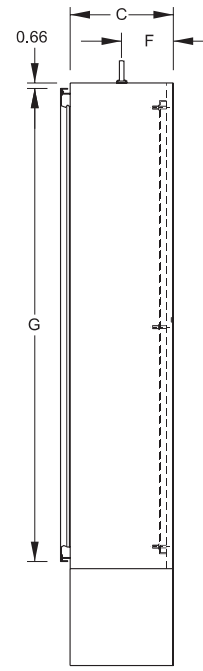
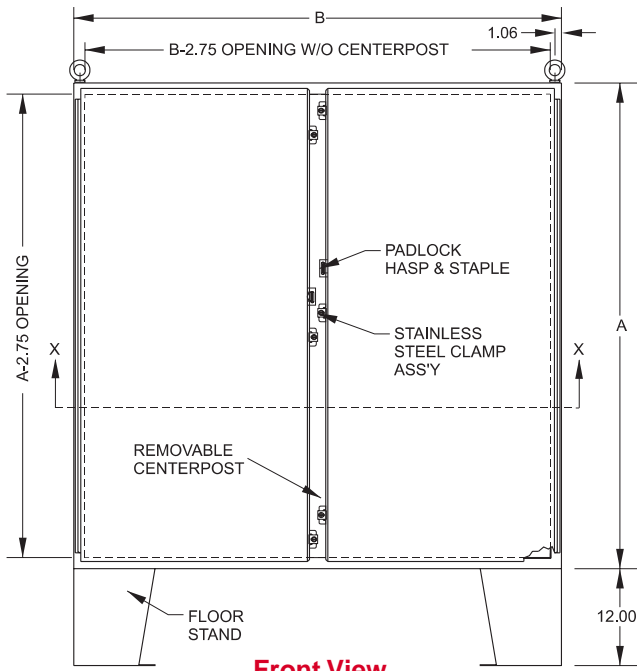

Part No.	A	B	C	Body Gauge	Panel Gauge	Panel Size		F	G	H	J	Ship Wt. lbs.
1422N4B10F	60.13	48.06	10.69	12	10	56	44	5.3	58.59	22	9.87	475
1422N4D12F	60.13	60.06	12.69	12	10	56	56	6.3	58.59	28	11.87	567
1422N4E12F	72.13	60.06	12.69	12	10	68	56	6.3	70.59	28	11.87	645
1422N4F12F	72.13	72.06	12.69	12	10	68	68	6.3	70.59	34	11.87	750
1422N4F24F	72.13	72.06	24.69	12	10	68	68	12.3	70.59	34	23.87	945

1418 Series Single Door Freestanding Enclosures - NEMA 12

Single or Dual Access

Industrial Enclosures
Freestanding Enclosures



Order
Panel
Separately



Application

- Designed to house electrical, electronic, hydraulic or pneumatic controls with provision for panel mounting or rack mounting of equipment.
- Provides a degree of protection from falling dirt, dust, oil and water.
- Available with front access only or both front and rear access.
- A variety of inner panels, rack mounting rails and swing out frames are available to provide flexibility in mounting arrangements.

Standards

- UL 508 Type 12
- CSA Type 12
- **Complies with**
 - NEMA Type 12
 - IEC 529, IP65

Construction

- Formed 12 gauge steel.
- Smooth, continuously welded seams without knockouts, cutouts or holes.
- Lifting eyes provide for easy enclosure handling.
- Doors are supported with heavy gauge continuous hinges.
- Doors are secured with a three point latch and operated with a key locking automotive type handle.
- Latch rods are equipped with rollers for easier door closing.
- Oil resistant gaskets are permanently secured and mechanically retained.
- Mounting channels are welded on the inside of the enclosure for mounting of optional inner panels or rack equipment rails.
- A grounding stud is provided in the enclosure and a bonding stud is provided on the door.
- A literature pocket is provided for the inside of the door (Two pockets are provided for dual access units).

Finish

- Cover and enclosure are finished in recoatable smooth ANSI/ASA 61 gray powder coating on the outside, with white powder coating on the inside.
- Optional inner panels, rails, frames and supports are finished in white powder coating.

Accessories

- Air conditioners...see page **348-357**
- Blowers...see page **359**
- Breather kits...see page **374**
- Door stop kits...see page **393**
- Drip shield kits...see page **393**
- Filter fans...see page **360-367**
- Heaters...see page **369-371**
- Inner panels...see page **64**
- Light kit...see page **393**
- Louvered ventilating plates...see page **396**
- Panel rails...see page **65**
- Swing frames...see page **65**
- Thermostats...see page **374**
- Window kits...see page **391**

1418 Series Single Door Freestanding Enclosures - NEMA 12

Single or Dual Access

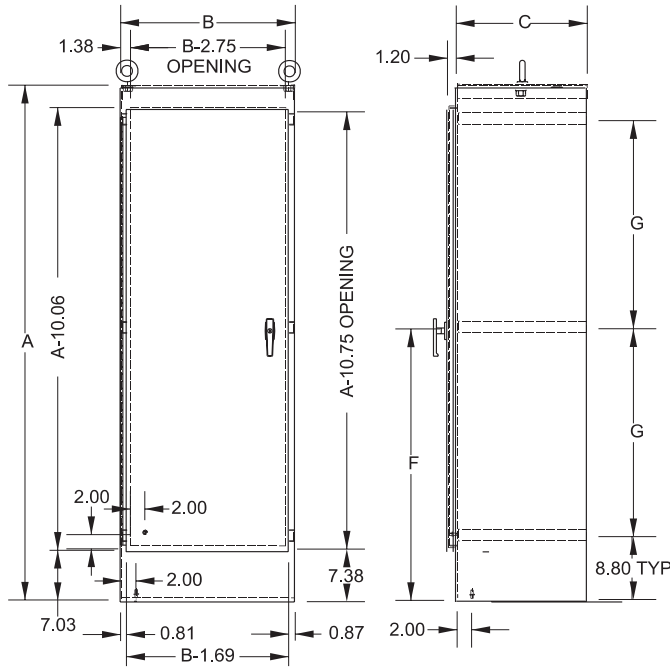

**Single Access-
Front View**

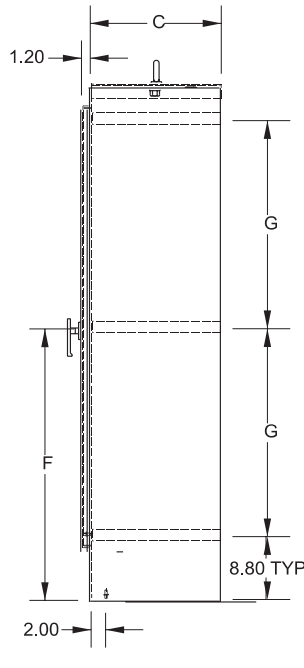

**Single Access-
Side View**

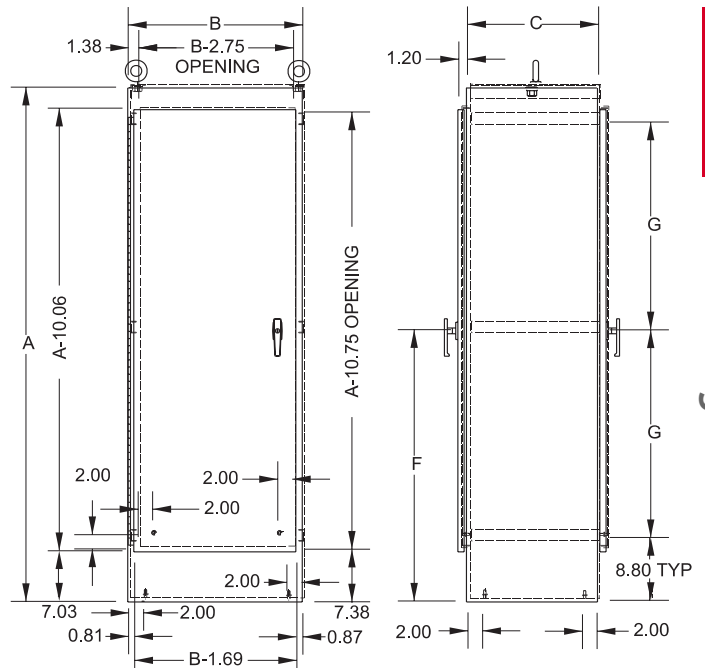

**Dual Access-
Front View**

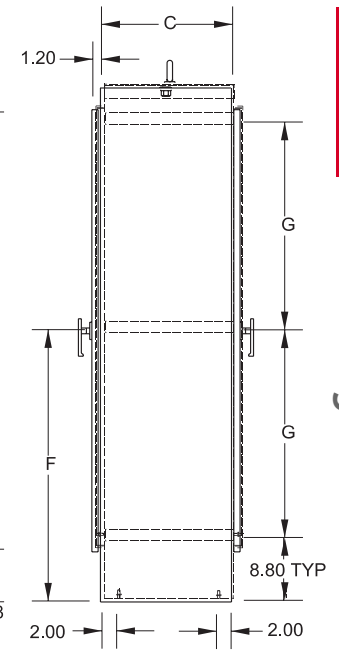

**Dual Access-
Side View**

Note: 4 eyebolts are provided for 30.06" and 36.06" deep enclosures (both dual and single access)

Single Access

Part No.	A	B	C	F	G	Optional Full Panel ¹	Ship Wt. lbs.
1418TW18	60.06	24.06	18.06	32.03	23.13	60TWWF	210
1418W18	72.06	24.06	18.06	38.03	29.13	72WFW	246
1418X18	72.06	30.06	18.06	38.03	29.13	72XFW	285
1418Y18	72.06	36.06	18.06	38.03	29.13	72YFW	325
1418YW20	90.06	24.06	20.06	47.03	38.13	90YFW	313
1418YY20	90.06	36.06	20.06	47.03	38.13	90YFW	406
1418TY24	60.06	36.06	24.06	32.03	23.13	60TYFW	325
1418W24	72.06	24.06	24.06	38.03	29.13	72WFW	300
1418X24	72.06	30.06	24.06	38.03	29.13	72XFW	335
1418Y24	72.06	36.06	24.06	38.03	29.13	72YFW	370
1418YY24	90.06	36.06	24.06	47.03	38.13	90YFW	440
1418W30	72.06	24.06	30.06	38.03	29.13	72WFW	355
1418Y30	72.06	36.06	30.06	38.03	29.13	72YFW	420
1418W36	72.06	24.06	36.06	38.03	29.13	72WFW	400
1418Y36	72.06	36.06	36.06	38.03	29.13	72YFW	465
1418YY36	90.06	36.06	36.06	47.03	38.13	90YFW	525

¹ Refers to Optional Full Height/Full Width Panels. Depth Panels & Half Height Width panels are also available...see page 64.

Dual Access

Part No.	A	B	C	F	G	Optional Full Panel ¹	Ship Wt. lbs.
1418WD24	72.06	24.06	24.06	38.03	29.13	72WFW	325
1418XD24	72.06	30.06	24.06	38.03	29.13	72XFW	424
1418YD24	72.06	36.06	24.06	38.03	29.13	72YFW	474
1418YYD24	90.06	36.06	24.06	47.03	38.13	90YFW	540
1418WD30	72.06	24.06	30.06	38.03	29.13	72WFW	375
1418WD36	72.06	24.06	36.06	38.03	29.13	72WFW	425
1418YD36	72.06	36.06	36.06	38.03	29.13	72YFW	495
1418YYD36	90.06	36.06	36.06	47.03	38.13	90YFW	555

¹ Refers to Optional Full Height/Full Width Panels. Depth Panels & Half Height Width panels are also available...see page 64.

Maximum Useable Depth

Single Access only
From inside surface of front door to front face of Full Width Panel
Inner Panel in Full Back Position

Enclosure Depth (In.)	Maximum Usable Depth
18.06	17.80
20.06	19.80
24.06	23.80
30.06	29.80
36.06	35.80

1418 N4 Series Freestanding Enclosures - NEMA 4, 12

Single Door

Industrial Enclosures
Freestanding Enclosures



**Order
Panel
Separately**



Application

- Designed to house electrical, electronic, hydraulic or pneumatic controls with provision for panel mounting or rack mounting of equipment.
- Provides protection where equipment may be hosed down or otherwise be very wet, or in specific applications where corrosion is a serious problem.
- A variety of inner panels, rack mounting rails and swing out frames are available to provide flexibility in mounting arrangements.

Standards

- UL 508 Type 3R, 4 and 12
- CSA Type 3R, 4 and 12
- **Complies with**
 - NEMA Type 3R, 4, 12 and 13
 - IEC 529, IP66

Construction

- Formed 12 gauge steel.
- Smooth, continuously welded seams without knockouts, cutouts or holes.
- Lifting eyes provide for easy enclosure handling.
- Doors are supported with heavy gauge continuous hinges.
- Doors are secured with heavy duty stainless steel clamps.
- Oil resistant gaskets are permanently secured and mechanically retained.
- Mounting channels are welded on the inside of the enclosure for mounting of optional inner panels or rack equipment rails.
- A grounding stud is provided in the enclosure and a bonding stud is provided on the door.

Finish

- Cover and enclosure are finished in recoatable smooth ANSI/ASA 61 gray powder coating on the outside, with white powder coating on the inside.
- Optional inner panels are finished in white powder coating.

Accessories

- Air conditioners...see page **348-357**
- Breather kits...see page **374**
- Door stop kits...see page **393**
- Drip shield kits...see page **393**
- Filter fans...see page **360-367**
- Heaters...see page **369-371**
- Light kit...see page **393**
- Panel rails...see page **65**
- Inner panels...see page **64**
- Swing frames...see page **65**
- Thermostats...see page **3714**
- Window kits...see page **391**

1418 N4 Series Freestanding Enclosures - NEMA 4, 12

Single Door

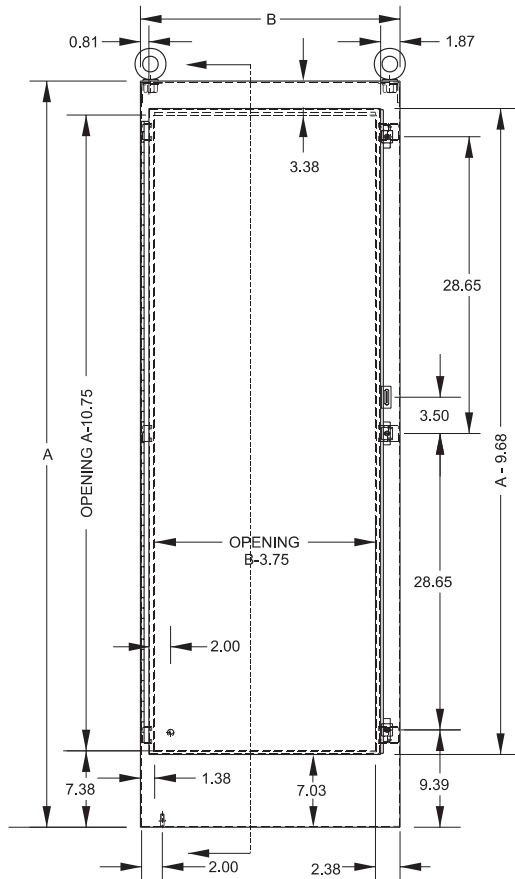

Front View

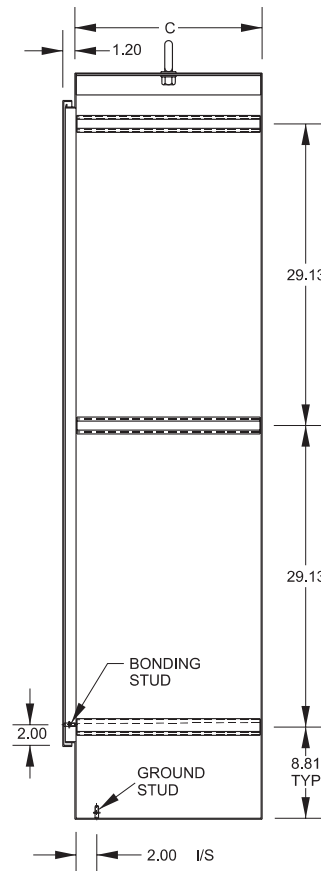

Cross Section Side View

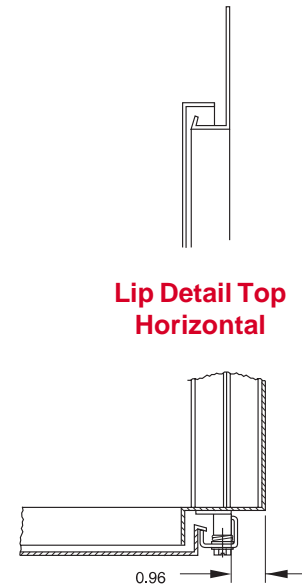

Lip Detail Top Horizontal

Vertical Cross Section

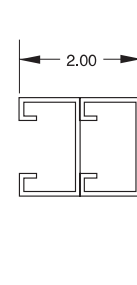

Strut Detail Right Side

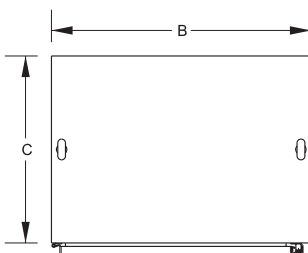

Top View

Part No.	A	B	C	Optional Full Panel ¹	Ship Wt. lbs.
1418N4W18	72.06	25.06	18.06	72WFW	290
1418N4X24	72.06	31.06	24.06	72XFW	250
1418N4Y24	72.06	37.06	24.06	72YFW	390

¹ Refers to Optional Full Height/Full Width Panels. Depth Panels & Half Height Width panels are also available....see page 64.

1418 Series Two Door Freestanding Enclosures - NEMA 12

Single or Dual Access

Industrial Enclosures
Freestanding Enclosures



Order
Panel
Separately



Application

- Designed to house electrical, electronic, hydraulic or pneumatic controls with provision for panel mounting or rack mounting of equipment.
- Provides a degree of protection from falling dirt, dust, oil and water.
- Available with front access only or both front and rear access.
- A variety of inner panels, rack mounting angles and swing frames are available to provide flexibility in equipment mounting.

Standards

- UL 508 Type 12
- CSA Type 12
- **Complies with**
 - NEMA Type 12
 - IEC 529, IP65

Construction

- Formed 12 gauge steel (10 gauge on back of single access enclosures).
- Smooth, continuously welded seams without knockouts, cutouts or holes.
- Stiffeners on the rear of the enclosure provide rigidity.
- Lifting eyes provide for easy enclosure handling.
- Doors are supported with heavy gauge continuous hinges.
- Doors are secured with a three point latch and operated with a key locking automotive type handle.
- Latch rods are equipped with rollers for easier door closing.
- Oil resistant gaskets are permanently secured and mechanically retained.
- Mounting channels are welded on the inside of the enclosure for mounting of optional inner panels or rack equipment rails.
- A bonding stud is provided on the door and a grounding stud is provided in the enclosure for each door.
- A literature pocket is provided for the inside of the door (Two pockets are provided for dual access units).

Finish

- Cover and enclosure are finished in recoatable smooth ANSI/ASA 61 gray powder coating on the outside, with white powder coating on the inside.
- Optional inner panels, rails, frames and supports are finished in white powder coating.

Accessories

- Air conditioners...see page **348-357**
- Blowers...see page **359**
- Breather kits...see page **374**
- Center panel support...see page **64**
- Door stop kits...see page **393**
- Drip shield kits...see page **393**
- Filter fans...see page **360-367**
- Heaters...see page **369-371**
- Inner panels...see page **64**
- Light kit...see page **393**
- Louvered ventilating plates...see page **396**
- Panel rails...see page **65**
- Swing frames...see page **64**
- Thermostats...see page **374**
- Window kits...see page **391**

1418 Series Two Door Freestanding Enclosures - NEMA 12

Single or Dual Access

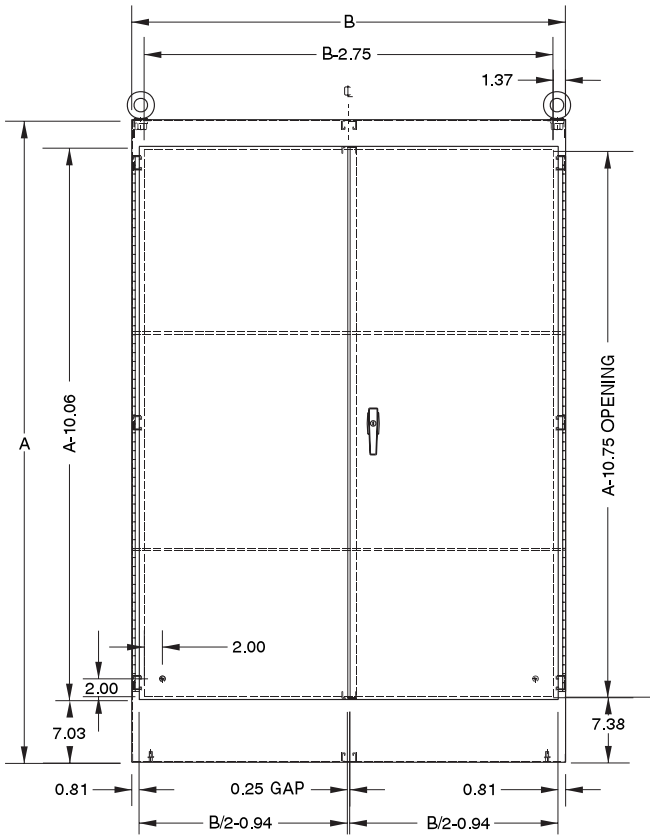

Single or Dual Access - Front View

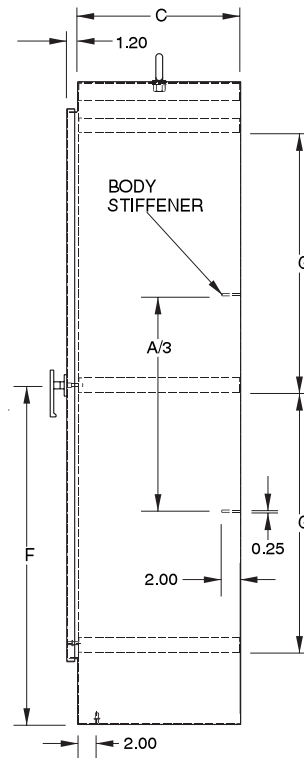

Single Access - Side View

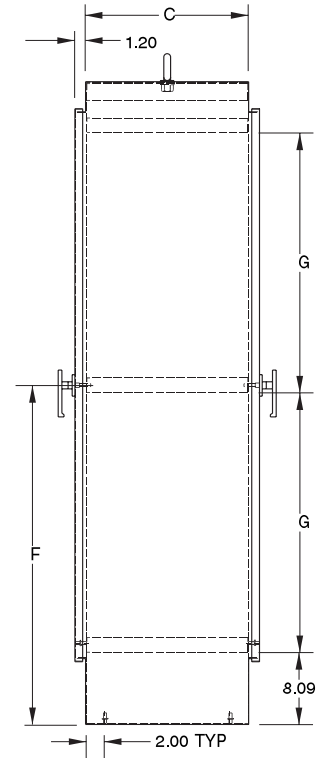

Dual Access - Side View

Industrial Enclosures
Freestanding Enclosures

Note: 4 eyebolts are provided for 36.06" deep enclosures (both dual and single access)

Single Access

Part No.	A	B	C	F	G	Optional Full Panel ¹	Ship Wt. lbs.
1418AW18	60.06	48.06	18.06	32.03	23.13	60AWFW	550
1418ZW18	72.06	48.06	18.06	38.03	29.13	72ZWFW	575
1418ZX18	72.06	60.06	18.06	38.03	29.13	72ZXFW	625
1418ZY18	72.06	72.06	18.06	38.03	29.13	72ZYFW	700
1418BW20	90.06	48.06	20.06	47.03	38.13	90BWFW	650
1418BY20	90.06	72.06	20.06	47.03	38.13	90BYFW	900
1418BY24	90.06	72.06	24.06	47.03	38.13	90BYFW	950
1418ZW24	72.06	48.06	24.06	38.03	29.13	72ZWFW	600
1418ZX24	72.06	60.06	24.06	38.03	29.13	72ZXFW	650
1418ZY24	72.06	72.06	24.06	38.03	29.13	72ZYFW	740
1418ZX36	72.06	60.06	36.06	38.03	29.13	72ZXFW	850
1418BY36	90.06	72.06	36.06	47.03	38.13	90BYFW	1100

¹ Refers to Optional Full Height/Full Width Panels. Depth Panels & Half Height Width panels are also available...see page 64.

Dual Access

Part No.	A	B	C	F	G	Optional Full Panel ¹	Ship Wt. lbs.
1418ZWD24	72.06	48.06	24.06	38.03	29.13	72ZWFW	625
1418ZXD24	72.06	60.06	24.06	38.03	29.13	72ZXFW	650
1418ZYD24	72.06	72.06	24.06	38.03	29.13	72ZYFW	725
1418BYD24	90.06	72.06	24.06	47.03	38.13	90BYFW	1000
1418ZXD36	72.06	60.06	36.06	38.03	29.13	72ZXFW	900

¹ Refers to Optional Full Height/Full Width Panels. Depth Panels & Half Height Width panels are also available...see page 64.

1418 Series Freestanding Enclosures - NEMA 4, 12

Accessories

Inner Panels

- Formed from 10 gauge or 12 gauge steel.
- All double door width panels are 10 gauge steel.
- Width panels are available in full or half height.
- Depth panels are available in full height only.
- Depth and width panels are provided with all mounting hardware and center support where required.
- Half panel can be mounted in the top or bottom half of the enclosure.
- Finished in white.

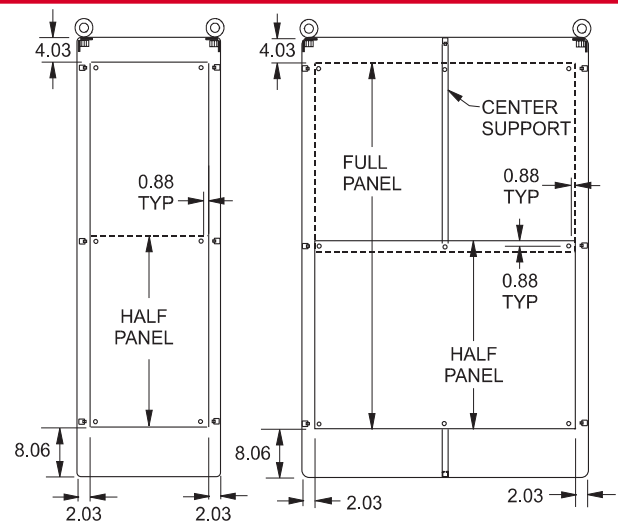

**Front View
Single Door**

**Front View
Double Door**

Depth Panels

Side Mounted Panels for Single and Double Door Enclosures

Part No.	Encl. Height	Panel Width	Panel Height
60FD14	60	14	48
72FD9	72	9	60
72FD14	72	14	60
72FD20	72	20	60
72FD26	72	26	60
90FD9	90	9	78
90FD14	90	14	78
90FD20	90	20	78
90FD26	90	26	78

Double Door Width Panels

Part No.	Description	Enclosure	Panel Size
60AWFW	Full Panel	60 x 48	48.00 x 44
60AWHW	Half Panel		24.88 x 44
72ZFW	Full Panel	72 x 48	60.00 x 44
72ZHW	Half Panel		30.88 x 44
72ZFW	Full Panel	72 x 60	60.00 x 56
72ZHW	Half Panel		30.88 x 56
72ZFW	Full Panel	72 x 72	60.00 x 68
72ZHW	Half Panel		30.88 x 68
90BFW	Full Panel	90 x 48	78.00 x 44
90BHW	Half Panel		39.88 x 44
90BFW	Full Panel	90 x 72	78.00 x 68
90BHW	Half Panel		39.88 x 68

Single Door Width Panels

Part No.	Description	Enclosure	Panel Size
60TWF	Full Panel	60 x 24	48.00 x 20
60TWH	Half Panel		24.87 x 20
72WF	Full Panel	72 x 24	60.00 x 20
72WH	Half Panel		30.87 x 20
90YWF	Full Panel	90 x 24	78.00 x 20
90YWH	Half Panel		39.87 x 20
72XFW	Full Panel	72 x 30	60.00 x 26
72XHW	Half Panel		30.87 x 26
60TYFW	Full Panel	60 x 36	48.00 x 32
60TYHW	Half Panel		24.87 x 32
72YFW	Full Panel	72 x 36	60.00 x 32
72YHW	Half Panel		30.87 x 32
90YFW	Full Panel	90 x 36	78.00 x 32
90YHW	Half Panel		39.87 x 32

1418 CS Series Center Panel Supports

- Adapts panels, swing frames, and panel rails from single door enclosures so they can be used on double door enclosures.
- Suitable for single or dual access double door enclosures.
- Center panel support mounts into front to back mounting channels (top and bottom) found in two door enclosures.
- Allows a combination of two 20" panels in a 48" wide enclosure, two 26" panels in a 60" wide enclosure, or two 32" panels in a 72" wide enclosure.
- Width is adjustable from 1.91" to 2.34".
- Support may be positioned at any depth within the enclosure.
- Finished in white.

Part No.	Enclosure Ht.
1418ACS	60
1418ZCS	72
1418BCS	90

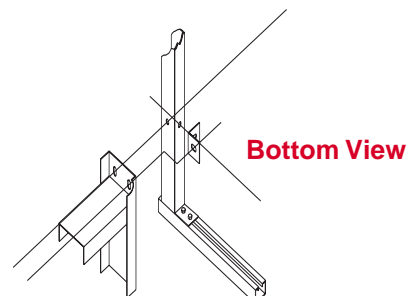

Bottom View

1418 Series Freestanding Enclosures - NEMA 4, 12

Accessories

Panel Rails

- Provides 19" or 24" mounting capability.
- Sold in **pairs**.
- Formed from 10 gauge steel.
- Drilled and tapped 10-32 to EIA spacing of 0.5" - 0.63" - 0.63" - 0.5".
- Finished in white.



Part No.	Panel Description	Angle Enclosure	Width	Panel Height	U	V
1418TFHP	Full Height	60 x 24	19	49.00	3.78	7.78
1418THHP	Half Height			26.25	3.59	7.59
1418WFHP	Full Height	72 x 24	19	61.25	3.66	7.66
1418WHHP	Half Height			31.50	3.97	7.67
1418XFHP	Full Height	72 x 30	24	61.25	3.66	7.66
1418XHHP	Half Height			31.50	3.97	7.67
1418YFHP	Full Height	90 x 24	19	78.75	3.91	7.91
1418YHHP	Half Height			40.25	4.09	8.09

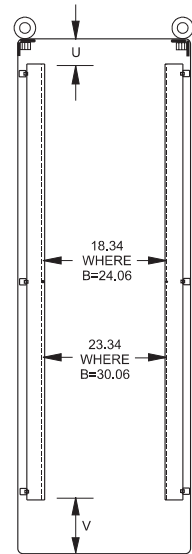

Swing Out Frames For 19" Rack Mounting

- Formed from 10 gauge steel, frames are drilled and tapped to EIA requirements for mounting standard 19" rack accessories.
- Designed for installation in 72" and 90" high enclosures. The swing frame pivots on 0.5" pins within the enclosure for easy access to the rear of rack mounted equipment.
- The frame positions at any depth within the enclosure and is fastened in the closed position with quarter turn fasteners.
- Swing frames may be mounted in 30" and 36" wide enclosures, or in 60" and 72" wide enclosures with an optional center panel support...see page 64.
- One or two frames may be mounted in 30" and 36" wide enclosures with dual access, and 1,2,3 or 4 frames may be mounted in 60" and 72" wide dual access enclosures.
- Finished in black.

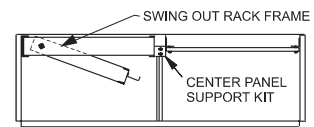
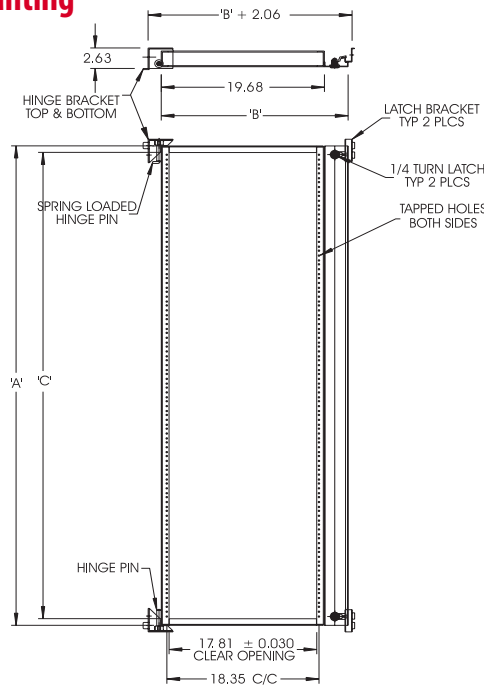

Section View from Top of Cabinet

Part No.	A	B	C	D	E	Enclosure Height	Width Single Door	Width Double Door	Center Support
1418SFYY	87.86	33.72	4.28	78.5	75.31	90	36	72	1418 BCS
1418SFY	69.86	33.72	4.28	60.5	57.81	72	36	72	1418 ZCS
1418SFX	69.86	27.72	4.28	60.5	57.81	72	30	60	1418 ZCS

Note: When using a swing out frame on a double door enclosure, a Center Panel Support must also be used and ordered separately...see previous page.

1422 MD Series Multiple Door Enclosures - NEMA 12

Continuous Hinge, Padlockable Doors

Industrial Enclosures
Freestanding Enclosures



Inner Panel Included



Application

- Designed to house electrical, electronic, hydraulic or pneumatic controls and instruments.
- Provides a degree of protection from falling dirt, dust, oil and water.

Standards

- UL 508 Type 12
- CSA Type 12
- **Complies with**
 - NEMA Type 12
 - JIC EGP-1-1967
 - IEC 529, IP65

Construction

- Formed 10 gauge steel.
- Smooth, continuously welded seams without knockouts, cutouts or holes.
- Heavy duty body stiffeners are provided for extra rigidity.
- Reinforced eyebolts are provided for easy enclosure lifting.
- Double door openings have gasketed overlapping doors, eliminating the need for a center post.
- Continuously hinged doors may be removed by pulling the hinge pin.

- Doors are secured with a three point latch and operated with a vault type padlocking handle.
- Latch rods are equipped with rollers for easier door closing.
- Oil resistant gaskets are permanently secured and mechanically retained.
- Removable 10 gauge inner panels are included in the enclosures.
- 3 door units have 2 panels (34" x 78" and 70" x 78").
- 4 door units have 2 panels (70" x 78" each).
- 5 door units have 3 panels (one 34" x 78" and two 70" x 78").
- Slave doors have mechanical interlock and cannot be opened unless the master door is open.
- Panel supports are provided in enclosures for easy panel installation.
- Collar studs are provided for mounting inner panels.
- A grounding stud is provided in the enclosure for each door and a bonding stud is provided on the door.
- A literature pocket is provided for the inside of the door.

Finish

- Cover and enclosure are finished in recoatable smooth ANSI/ASA 61 gray powder coating on the outside, with white powder coating on the inside.
- Removable inner panels are finished in white powder coating.

Accessories

- Additional inner panels...see page **385**
- Air conditioners...see page **348-357**
- Blowers...see page **359**
- Breather kits...see page **374**
- Door stop kits...see page **393**
- Filter fans...see page **360-367**
- Heaters...see page **369-371**
- Thermostats...see page **374**
- Louvered ventilating plates...see page **396**
- Window kits...see page **391**

1422 MD Series Multiple Door Enclosures - NEMA 12

Continuous Hinge, Padlockable Doors

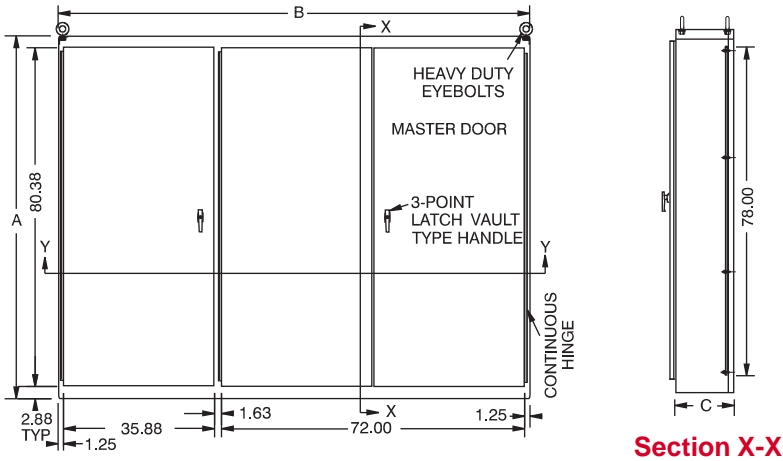

Part No.	A	B	C	Ship Wt. lbs.
1422MD3	86.12	112.00	14.12	1850
1422MD4	86.12	149.12	14.12	2270
1422MD5	86.12	187.00	14.12	2900

Industrial Enclosures
Freestanding Enclosures



Section X-X

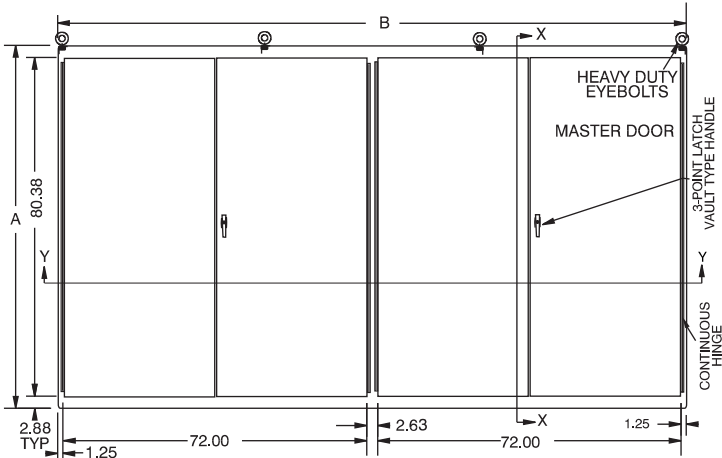

Section X-X

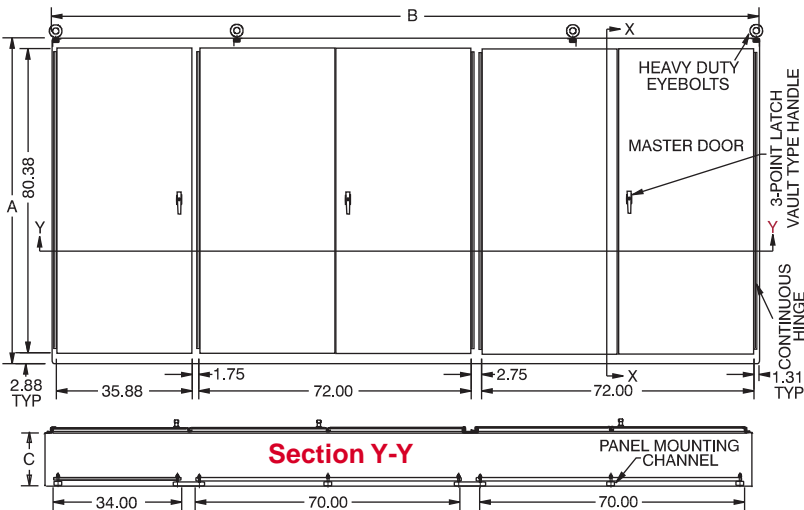
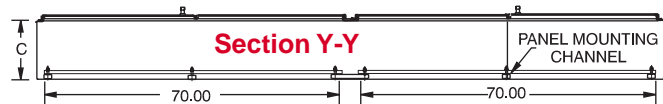

Section X-X

Technical references and DXF downloads available at www.hammg.com

All dimensions in inches unless specified otherwise

Quality Enclosures. Service Excellence.